

# MUSKEGON



**West Michigan's Shoreline City**

**WFP-22-001**

***ROBERTS STREET TANK/EXTERIOR  
PAINTING, DRY INTERIOR PAINTING, AND  
WET INTERIOR SPOT PAINTING***

***BID DOCUMENTS***

***ENGINEERING  
PUBLIC WORKS & UTILITIES  
CITY HALL  
49440***

**TABLE OF CONTENTS**

**INTRODUCTION**

INVITATION FOR BIDS .....2  
NOTICE OF REQUIREMENT FOR AFFIRMATIVE ACTION .....3  
DEFINITIONS.....4

**PART 1 - BIDS**

**SECTION 1 – INSTRUCTIONS TO BIDDERS .....7**  
1.0 INSTRUCTIONS TO BIDDERS .....8  
**SECTION 2 - BID PROPOSAL .....14**  
1.1 CONTRACT BIDDER’S CHECKLIST.....15  
] 1.3 BIDDER CERTIFICATION & AGREEMENT.....17  
1.4 BID BOND .....19  
1.5 NON-COLLUSION AFFIDAVIT OF PRIME BIDDER.....21  
1.6 LIST OF PROPOSED SUBCONTRACTORS .....22  
1.7 DISADVANTAGED CONTRACTOR AFFIDAVIT .....23  
1.8 STATEMENT OF BIDDER’S QUALIFICATIONS .....24  
1.9 DBE/MBE/WBE PROCUREMENT POLICY .....26  
1.10 BID TABULATUION .....29

**PART 2 - AGREEMENT**

2.0 AWARDEE CHECKLIST.....35  
2.1 DIRECTIONS FOR PREPARATION .....36  
2.2 AGREEMENT .....37  
2.3 PERFORMANCE BOND.....39  
2.4 LABOR & MATERIALMAN’S BOND .....41  
2.5 NON-COLLUSION AFFIDAVIT OF SUBCONTRACTOR .....43  
2.6 LETTERS OF RECOMMENDATION IN LIEU OF PERFORMANCE BOND.....44

**PART 3 – GENERAL SPECIFICATIONS**

**SECTION 1 – PROJECT PERFORMANCE .....46**  
3.0 PROJECT PERFORMANCE .....47  
3.1 TIME CHANGE ORDER .....63  
3.2 CONTRACT CHANGE ORDER.....64  
3.3 CONTRACTOR’S CERTIFICATE & RELEASE REQUEST FOR FINAL PAYMENT.....65  
3.4 CONTRACTOR AFFIDAVIT - SURETY RELEASE .....67  
3.5 CONSENT OF SURETY .....68  
**SECTION 2 .....69**  
3.6 AFFIRMATIVE ACTION .....70  
**SECTION 3 .....71**  
3.7 ADOPTED LABOR STANDARDS PROVISIONS .....72  
3.8 EQUAL OPPORTUNITY CLAUSE.....73  
3.9 ANTI-KICKBACK ACT.....74  
**SECTION 4 .....75**  
3.10 PREVAILING WAGE DECISION .....76

<b>Section 00 91 187– Additions to General Conditions.....</b>	<b>1-19</b>
<b>Section 00 91 18 – Definitions for Technical Specifications .....</b>	<b>20</b>
<b>Section 00 91 19.01 – Scheduling for RPR Services.....</b>	<b>21-26</b>
<b>Section 00 91 19.02 – Contractor’s Financial Responsibility for RPR.....</b>	<b>27-29</b>
<b>Section 01 50 00 – Temporary Construction Facilities and Utilities .....</b>	<b>30-32</b>
<b>Section 01 53 43 – Protection of Environment .....</b>	<b>33-36</b>
<b>Section 03 01 30 – Maintenance of Cast-In-Place Concrete.....</b>	<b>37-42</b>
<b>Section 05 00 00 – Metal Repairs.....</b>	<b>43-48</b>
<b>Drawing 01 ..... Roof Hatch Hasp</b>	
<b>Drawing 02a .... Overflow Discharge</b>	
<b>Drawing 02b .... 6 Inch Overflow Flap Gate</b>	
<b>Drawing 03 ..... Bowl Rigging Couplings</b>	
<b>Drawing 04 ..... Painter’s Railing Support</b>	
<b>Section 09 97 13 – Steel Coating .....</b>	<b>49-59</b>
<b>Section 09 97 13.10 – Steel Coating Surface Preparation.....</b>	<b>60-64</b>
<b>Section 09 97 13.12 – Heavy Metal Bearing Paint Removal and Disposal.....</b>	<b>65-67</b>
<b>Section 09 97 13.14.01 – Wet Interior Steel Coating – Repair 2 Coat Epoxy.....</b>	<b>68-69</b>
<b>Section 09 97 13.18.01 – Dry Interior Steel Coating – Epoxy System .....</b>	<b>70-71</b>
<b>Section 09 97 13.24.08 – Exterior Steel Coating – 3 Coat Epoxy Urethane.....</b>	<b>72-73</b>
<b>Overcoat</b>	
<b>Section 09 97 23.23.01 – Concrete Foundation Coating – 2 Coat Epoxy .....</b>	<b>74</b>
<b>Section 13 32 12 – Mixing System - Gridbee .....</b>	<b>75-79</b>
<b>Section 16 05 04 –Electrical – Electric Conduit and Lighting .....</b>	<b>80-82</b>

## INVITATION FOR BIDS

**Project: Roberts Street Tank Exterior, Dry Interior Painting, and Wet Interior Spot Painting  
WFP-22-001**

**The City of Muskegon, Michigan will receive sealed bids until 2:00 p.m. local time on Tuesday, April 5, 2022, at the City Clerk's Office, City Hall, 933 Terrace Street, Muskegon, Michigan, at which time and place all bids will be publicly opened and read aloud for the following items of work to include:**

### ***PROJECT DETAILS.***

The structure is a 1,000,000 gallon radial arm water storage tank (Roberts Tank) with an estimated high-water level of 120 ft. located at 712 Roberts St. in Muskegon, Michigan.

Exterior: High pressure water clean (5,000 to 10,000 psi), spot power tool clean to a SSPC-SP11 standard and apply a three (3) coat epoxy urethane system.

Wet Interior: Spot abrasive blast clean the coating failures to a SSPC-SP10 near-white metal standard and apply a two (2) coat epoxy system.

Dry Interior: Abrasive blast clean the entire access leg interior and access tube interior to a SSPC-SP6 commercial standard and apply a three (3) coat epoxy system.

Foundation: Remove shrubs adjacent to foundation. Repair spalls. Water clean and apply a two (2) coat epoxy system.

Mixer: Install a mechanical mixer.

### Repairs:

- 1) Replace the riser manway gaskets.
- 2) Install a gasket on the wet interior roof hatch.
- 3) Install a hasp on the wet interior roof hatch.
- 4) Install a handhold at the wet interior roof hatch.
- 5) Overflow discharge modification.
- 6) Adjust fall prevention device on the dry interior access tube and wet interior ladders.
- 7) Install bowl rigging couplings.
- 8) Install painter's railing stand-offs.
- 9) Patch plate on the wet interior platform
- 10) Weld a plate around the overflow penetration at the bottom of the access tube.
- 11) Access leg drain holes.
- 12) Replace light fixtures.
- 13) Electrical conduit repair.
- 14) Change all light bulbs in the dry interior.

Work hours are 7:00A.M. to 6:00P.M. seven days a week.

Electronic copies of Plans and Specifications may be obtained on or after Tuesday, March 22, 2022 from the City of Muskegon website, or by request to the Water Filtration Plant via phone or email; 231.724.4104 or [joe.buthker@shorelinecity.com](mailto:joe.buthker@shorelinecity.com).

An amount equal to five percent (5%) of the Bid must be submitted with each Bid Proposal in one of three forms acceptable to the City of Muskegon.

Contract documents may be examined at the following locations:

- Water Filtration Plant, 1900 Beach Street, Muskegon, MI 49441
- City of Muskegon website: [www.shorelinecity.com](http://www.shorelinecity.com)

Attention is called to the fact that the City requires: the Contractor consider hiring local work force insofar as possible, not less than the salaries and wages set forth in the Specifications must be paid, 14% minority and 6.9% female are the goals established for participation in each trade, the Contractor must ensure employees and applicants for employment are not discriminated against based upon their race, creed, color, religion, sex, national origin, handicapped condition nor veteran background, and all pertinent regulations must be complied with. Bids may not be withdrawn within sixty (60) days after bid opening. The City of Muskegon reserves the right to reject any or all bids or to waive any informalities or irregularities in the bidding.

CITY OF MUSKEGON, MICHIGAN

By: Ann Meisch, City Clerk

PUBLISH: **04/05/2022**

#### **ADA POLICY**

The City will provide necessary appropriate auxiliary aids services, for example, signers for the hearing impaired, audio tapes for the visually impaired, etc., for disabled persons who want to attend the meeting, upon twenty-four hour notice to the City. Contact:

**Ann Meisch, City Clerk  
City of Muskegon, City Hall  
933 Terrace Street, Muskegon, MI 49440  
(231) 724-6705 or TDD (231) 724-6773**

NOTICE OF REQUIREMENT FOR AFFIRMATIVE ACTION

Executive Order 11246

1. The Bidder's attention is called to the "Equal Opportunity Clause" and the "Standard Adopted Equal Employment Specifications" set forth in Part 3, Section II, of these Documents.
2. The goals and the timetables for minority and female participation, expressed in percentage terms for the Contractor's aggregate workforce in each trade on all construction work in the covered area, are as follows:

**GOALS FOR PARTICIPATION IN EACH TRADE**

TRADE	MINORITY	FEMALE
<b>ALL</b>	<b>14%</b>	<b>6.9%</b>

These goals are applicable to all the Contractor's construction work (whether or not it is Federal or Federally-assisted) performed in the covered area. If the Contractor performs construction work in a geographical area located outside of the covered area, it shall apply the goals established for such geographical area where the work is actually performed. With regard to this second area, the Contractor also is subject to the goals for both its federally involved and non-federally involved construction.

The Contractor's compliance with the Executive Order and regulations in 41 CFR Part 60-4 shall be based on its implementation of the Equal Opportunity Clause, specific affirmative action obligations required by the specifications set forth in 41 CFR 60-4.3(a), and its efforts to meet the goals. The hours of minority and female employment and training must be substantially uniform throughout the length of the Contract, and in each trade, and the Contractor shall make a good faith effort to employ minorities and women evenly on each of its projects. The transfer of minority or female employees or trainees from contractor to contractor or from project to project for the sole purpose of meeting the contractor's goals shall be a violation of the Contract, the Executive Order, and the regulations in 41 CFR Part 60-4. Compliance with the goals will be measured against the total work hours performed.

3. The Contractor shall provide written notification to the Director of the Office of Federal Contract Compliance Programs within 10 working days of award of any construction subcontract in excess of \$10,000 at any tier for construction work under the Contract resulting from this solicitation. The notification shall list the name, address and telephone number of the subcontractor; employer identification number of the subcontractor; estimated dollar amount of the subcontract; estimated starting and completion dates of the subcontract; and the geographical area in which the contract is to be performed.
4. As used in this Notice, and in the Contract resulting from this solicitation, the "covered area" is the City of Muskegon, County of Muskegon, and State of Michigan.

## DEFINITIONS

Whenever used anywhere in these Documents, the following meanings shall be given to the terms defined:

**ADDENDA or ADDENDUM** – Any changes, revisions, additions or clarifications of or to the Contract Documents which have been duly issued by the City to Bidders prior to the time of awarding or executing the Contract Agreement.

**AUTHORIZED REPRESENTATIVE** – Any person or persons authorized to represent the City of Muskegon by its governing body for the purpose of directing or having in charge the work embraced in this Contract, acting directly or indirectly through the responsible party having general charge of this work, and/or for monitoring, coordinating and inspecting the work and activities involved.

**BID or BID PROPOSAL** – The written offer of the Bidder, on the form furnished by the City, for the work proposed.

**BID BOND/GUARANTY** – The security required in these Documents and furnished by the Bidder as a guaranty of good faith to enter into a contract for the work proposed.

**BIDDER or PRIME BIDDER** – That individual, corporation or firm submitting a proposal for consideration by the City to perform the work proposed in these Documents.

**CITY – CITY OF MUSKEGON** - The City of Muskegon and/or its authorized representative(s); also may be referred to in portions of these Documents as owner, grantee, local public agency, or local government.

**CITY COMMISSION** – The governing body of the City of Muskegon which retains the right of final approval of all contractors, subcontractors, contracts and payments under any contracts.

**CONTRACT** – The Agreement executed by the City and the Contractor, of which this section is a part.

**CONTRACT DOCUMENTS** – Means and shall include the executed Agreement, any Addenda, Invitation for Bids, Instructions to Bidders, signed Bid Proposal, all Parts and Sections of the General, Technical and/or Special Specifications, any drawings, maps, plans, etc., and any forms or formats and documents included within the book forming these Documents.

**CONTRACT PERFORMANCE** – The act of complying with these Contract Documents to the successful completion of the Project by performing the work necessary to do so.

**CONTRACT PRICE** – That figure agreed upon through the bidding procedure as acceptable to the City and indicated as such in the Agreement executed by the Contractor and the City.

**CONTRACT TIME** – The date for completion or length of time until completion, of the work embraced in this Contract as stipulated in the Agreement executed by the Contractor and the City.

**CONTRACTOR or SUCCESSFUL BIDDER** – The person, corporation or firm whose bid was accepted by the City, resulting in the execution of the Agreement to perform the work under the terms of these Documents.

**DRAWINGS/PLANS** – Approved drawings or reproduction of drawings pertinent to the construction or details of the work covered by this Contract.

**LABORATORY** – The testing laboratory of the City or any other laboratory which may be designated by the City for the purpose of inspecting, examining and determining the suitability of materials and the quality of the products used in the performance of this Contract.

**LETTERS OF RECOMMENDATION – IN LIEU OF PERFORMANCE BOND** – Those statements presented by the Bidder to the City for consideration in lieu of a performance bond where applicable and in strict accordance with Part 1, Section I, paragraph 17(e), and the instructions in these Documents.

**PERFORMANCE/LABOR AND MATERIALMEN’S BONDS** – The statutory bonds, executed by the Contractor and a surety, guaranteeing the performance of the Contract and the payment of all lawful indebtedness pertaining thereto.

**PREVAILING WAGE DECISION** - That document, received from the U.S. Department of Housing and Urban Development or the State of Michigan Department of Labor as requested by the City, detailing the current wage rates which, if included in this Contract, are binding upon the Contractor and all subcontractors as the minimum wages to be paid during the life of this Contract.

**SITE** – Also referred to as **PROJECT SITE** or **PROJECT AREA**, indicating the location of the Project as generally described in these Documents.

**SUBCONTRACT** – An agreement executed by the Contractor with another individual, corporation or firm for work or a portion of the work embraced in this Contract. (An asterisk (\*) in the right-hand margin indicates subcontract language or requirements throughout Parts 1, 2 and 3 of these Documents.)

**SUBCONTRACTOR** – A person, corporation or firm supplying labor and/or materials for work at the Site of this Project for the Contractor under a Subcontract.

**SURETY** – The corporate body which is bound with and for the Contractor for the performance of this contract and for the payment of all lawful indebtedness pertaining thereto.

**SPECIFICATIONS – GENERAL** – Refers to specifications pertinent to the performance of any City Project anticipated to exceed \$2,000, as provided in Parts 1, 2 and 3 of these Documents.

**SPECIFICATIONS – TECHNICAL** – Refers to those Specifications pertinent to this Project and includes information regarding materials, products, etc., as provided in PART 4 of these Documents.

**SPECIFICATIONS – SPECIAL** – Refers to special information items pertinent to only this Project and includes Project Description, location, measurements, maps, drawings, etc.

**SPECIFICATIONS** – (without particular included as above) Refers to General Specifications, Technical Specifications and/or Special Specifications outlined in this Document.

**WORK ON (OR AT) THE PROJECT or PROJECT SITE** – Work to be performed under this Contract at the location of this Project, including transportation of materials and supplies to or from the Site by employees of the Contractor and/or Subcontractors.



**PART 1 - BIDS**

**SECTION 1 – INSTRUCTIONS TO BIDDERS**

## 1.0 INSTRUCTIONS TO BIDDERS

### 1.0.1 BIDS

- a. Bidding documents to be submitted must remain attached within this Contract Document.
- b. All bids submitted shall be on forms provided without alterations or interlineations and shall be subject to all requirements of these Instructions to Bidders and all the forms and Documents immediately following these Instructions in Section 2, Bid Proposal.
- c. All Bid Proposals submitted for consideration shall be enclosed in a sealed envelope which is clearly labeled "Bid Documents" with the Project name and/or number, the name of Bidder, the date and time of Bid Opening written on the envelope to prevent premature opening.
- d. If unit prices are requested, the Unit Price for each of the several items in the Bidder's proposal shall include its pro rata share of overhead so that the sum of the products obtained by multiplying the quantity for each item by the unit price represents the total bid. Should conditions make it necessary to revise the quantities, a limit will then be fixed for such increased or decreased quantities. Should the net monetary value of all such changes increase or decrease the original price by more than twenty-five percent (25%) negotiated price change shall be allowed, if warranted. Any bid not conforming to this requirement may be rejected.

### 1.0.2 BID GUARANTY

- a. No Bid will be considered unless it is accompanied by a Bid Guaranty of not less than five percent (5%) of the amount of the Bid to ensure the execution of the Contract and the furnishing of surety bond or bonds by the successful Bidder, as required by the Contract Documents. Cash deposits will not be accepted. Negotiable U.S. Government Bonds (at par value) and certified checks or bank drafts, made payable to the **City of Muskegon**, may be used, or a bid bond in the format provided which shall be secured by a guaranty or a surety company listed in the latest issue of U.S. Treasury Circular 570, and shall be within the maximum amount specified for such company in said Circular.
- b. Revised Bids submitted before the opening of Bids, whether forwarded by mail or telegraphic communication, if representing an increase in excess of two percent (2%) of the original bid, must have the Bid Guaranty adjusted accordingly; otherwise the Bid will not be considered.
- c. The Bid Guaranty of unsuccessful Bidders, or the amount thereof, will be returned as soon as practicable after the awarding of the contract. The Bid Guaranty of any Bidder withdrawing his/her Bid in accordance with the conditions set forth in Paragraph 13 hereof will be returned promptly.
- d. When telegraphic modifications of Bids are received as provided above, Bidders are cautioned that such modifications shall make the Bid as modified or amended subject to rejection if not explicit and/or in any sense are subject to misinterpretation.

### 1.0.3 ALTERNATIVE BIDS

No alternative bids will be considered unless alternative bids are specifically requested.

### 1.0.4 INTERPRETATIONS AND/OR ADDENDA

- a. No oral interpretation will be made to any Bidder as to the meaning of the Documents or any part thereof. A request for any interpretation will be in writing to the City of Muskegon, and any such request received seven (7) or more days before the scheduled Bid Opening will be considered.
- b. Every interpretation made will be in writing in the form of an Addendum to the Contract itself and, when issued, will be on file in the City Clerk's office at least five (5) days prior to the Bid Opening for each Bidder's review.

#### 1.0.5 BIDDER'S RESPONSIBILITIES

- a. Site Inspection. Each Bidder will assume the responsibility for visiting the site of the proposed work and for fully acquainting himself/herself with the conditions existing there relating to construction and labor, and should fully inform himself/herself as to the facilities involved, the difficulties and restrictions attending the performance of the Contract.
- b. Knowledge of Bid and Contract Documents. The Bidder is responsible for thoroughly examining and familiarizing himself/herself with the Bid and Contract Documents, any Drawings, Specifications and Addenda.
- c. Addenda to Contract Documents. All Bidders will assume the responsibility to make inquiry as to the Addenda issued, knowing that all such Addenda become part of the Contract. All Bidders shall be bound by any Addenda whether or not it was received or reviewed.
- d. Claims on Basis of Failure to Receive or Review Information. A successful Bidder, through the execution of this Contract, shall in no way be relieved of any obligation due to his/her failure to receive or examine any form or legal instrument, or due to the failure to visit the site and acquaint himself/herself with the existing conditions.  
The City Commission will be justified in rejecting any claims submitted on the basis of 5.a, b, or c above.

1.0.6 EQUAL OPPORTUNITY EMPLOYMENT REQUIREMENT - The attention of Bidders is particularly called to the requirement for ensuring that employees and applicants for employment are not discriminated against because of their race, color, religion, sex or national origin, nor because the employee or applicant is a disabled or Viet Nam era veteran or otherwise handicapped, as outlined in Part 3, Section 2 of these Documents.

1.0.7 EMPLOYMENT AND PREVAILING WAGE AND SALARY REQUIREMENTS - The attention of Bidders is particularly called to the requirements covered in Part 3, Section 4 of these Documents concerning the payment of not less than the prevailing wage and salary rates specified, and in regard to the conditions of employment with respect to certain categories and classifications of employees. These rates of pay are the minimums to be paid during the life of this Contract.

The City of Muskegon requires that the Contractor must hire local trades and labor employees from the City of Muskegon, County of Muskegon and/or this SMSA (Standard Metropolitan Statistical Area) for the duration of this Project, insofar as these are available to perform the necessary work. Supervisory and/or technical staff officials are exempt from this requirement.

It is therefore the responsibility of the Bidder to inform himself/herself as to local labor conditions, labor supply, overtime compensation, health and welfare contributions, and prospective changes or adjustments of rates.

1.0.8 SUBCONTRACTORS\* - Any Bidder submitting a Bid shall include a list of proposed subcontractors on the form provided in Part 1, Section 2 of these Documents.

The attention of Bidders is called to the Contractor's liability for all subcontractors as provided in the various sections and paragraphs on these Documents, generally indicated by an asterisk (\*) in the right-hand margin.

#### 1.0.9 NON-COLLUSION AFFIDAVIT

- a. Each Bidder submitting a bid for work, or any portion thereof, covered by these Documents, shall execute an Affidavit to the effect that he/she has not colluded with any other person, firm or

corporation in regard to any Bid submitted, in the same or similar format as provided in Part 1 Section 2 of these Documents.

- b. The successful Bidder shall secure an Affidavit to the same effect from any proposed subcontractor, before executing any subcontract, in the same or similar format as provided in Part 1, Section 2 of these Documents.

#### 1.0.10 SECTION 3 CLAUSE (135.38) FOR FEDERALLY FUNDED PROJECTS

- a. The work to be performed under this contract is subject to the requirements of section 3 of the Housing and Urban Development Act of 1968, as amended, 12 U.S.C. 1701u (section 3). The purpose of section 3 is to ensure that employment and other economic opportunities generated by HUD assistance or HUD-assisted projects covered by section 3, shall, to the greatest extent feasible, be directed to low- and very low-income person, particularly persons who are recipients of HUD assistance for housing.
- b. The parties to this contract agree to comply with HUD's regulations in 24 CFR part 135, which implement section 3. As evidenced by their execution of this contract, the parties to this contract certify that they are under no contractual or other impediment that would prevent them from complying with the part 135 regulations.
- c. The contractor agrees to send to each labor organization or representative or worker with which the contractor has a collective bargaining agreement or other understanding, if any, a notice advising the labor organization or workers' representative of the contractor's commitments under this section 3 clause, and will post copies of the notice in conspicuous places at the work site where both employees and applicants for training and employment positions can see the notice. The notice shall describe the section 3 preference, shall set forth minimum number and job titles subject to hire, availability of apprenticeship and training positions, the qualifications for each of the positions; and the anticipated date the work shall begin.
- d. The contractor agrees to include the section 3 clause in every subcontract subject to compliance with regulations in 24 CFR part 135, and agrees to take appropriate action, as provided in an applicable provision of the subcontract or in the section 3 clause, upon the finding that the subcontractor will not subcontract with any subcontractor where the contractor has notice or knowledge that the subcontractor has been found in violation of the regulations in 24 CFR part 135.
- e. The contractor will certify that any vacant employment positions, including training positions, that are filled (1) after the contractor is selected but before the contract is executed, and (2) with person other than those to whom the regulations of 24 CFR part 135 require employment opportunities to be directed, were not filled to circumvent the contractor's obligations under the 24 CFR part 135.
- f. Noncompliance with HUD's regulations in 24 CFR, part 135 may result in sanctions, termination of this contract for default, and debarment or suspension from future HUD assisted contracts.
- g. With respect to work performed in connections with section 3 covered Indian housing assistance, section 7(b) of the Indian Self-Determination and Education Assistance Act (25 U.S.C. 450e) also applies to the work to be performed under this contract. Section 7(b) requires that to the greatest extent feasible (i) preference and opportunities for training and employment shall be given to Indians, and (ii) preference in the award of contracts and subcontracts shall be given to Indian organizations and Indian-owned Economic Enterprises. Parties to this contract that are subject to the provisions of section 3 and section 7(b) agree to comply with section 3 to the maximum extent feasible, but not derogation of compliance with section 7(b).

Examples:

1. Who are Section 3 residents? – Residents of public housing and low income person who live in the area in which a HUD-assisted project is located.
2. What is a Section 3 business? – A business that is owned by Section 3 residents; or employs Section 3 residents in full-time positions; or subcontracts with businesses which provide economic opportunities to low income persons. (CDBG)
3. What types of economic opportunities are available under Section 3? – a. Administrative/Management: accounting, bookkeeping, payroll, purchasing, research, word processing b. Services: appliance repair, carpet installation, catering computer/information, florists, janitorial, landscaping, manufacturing, marketing, photography, printing, transportation C. Construction: architecture, bricklaying, carpentry, cement/masonry, demolition, drywall, electrical, elevator construction, engineering, fencing, heating, iron works, machine operation, painting, plastering, plumbing, surveying, tile setting.
4. Who will award the economic opportunities? – Recipients of HUD financial assistance and their contractors and subcontractors are required to provide economic opportunities to the greatest extent feasible, consistent with existing Federal, State and local laws and regulations.
5. Who receives priority under Section 3? – a. For training and employment: persons in public and assisted housing; person in the neighborhood; participants in HUD Youthbuild programs; homeless person b. For contracting: business which fit the definition of a Section 3 business.
6. How can businesses find Section 3 residents to work for them? - By recruiting in the neighborhood and public housing developments to tell them about available training and job opportunities. Distributing flyers, posting signs, placing ads, and contacting resident organizations and local community development and employment agencies to find potential workers are a few effective ways of getting jobs and people together.
7. How can businesses & low income people find out more about Section 3? Contact the Fair Housing and Equal Opportunity representative at your nearest HUD office.
8. What if it appears an entity is not complying with Section 3? - There is a complaint process. Section 3 residents and business concerns may file complaints if they think a violation of Section 3 requirements has occurred where HUD-funded project is planned or underway. Complaints will be investigated; if appropriate, voluntary resolutions will be sought. A complaint that cannot be resolved voluntarily can result in an administrative hearing.
9. Will HUD require compliance? – Yes. HUD investigates complaints and monitors the performance of recipients and contractors. HUD examines employment and contract records for evidence of actions taken to train and employ Section 3 residents and train and employ Section 3 residents and to award contracts to Section 3 businesses.
10. How can Section 3 businesses or residents complain about a violation of Section 3 requirements? – They can file a complaint in writing to the local HUD Office or to: The Assistant Secretary for Fair Housing and Equal Opportunity, U.S. Department of Housing and Urban Development 451 Seventh Street, SW, Rm. 5100 Washington, DC 20410-2000. A written complaint should contain:
  - a. Name and address of the person filing the complaint;
  - b. Name and address of subject of complaint (HUD recipient contractor);
  - c. Description of acts or omissions in alleged violation of section 3;
  - d. Statement of corrective action sought.

1.0.11 STATEMENT OF BIDDER’S QUALIFICATIONS; ADDITIONAL INFORMATION

- a. Upon request, each Bidder shall submit a Statement of Bidder’s Qualifications in accordance with the information requested in Part 1, Section 2, and, when specifically requested by the City, shall submit a detailed Financial Statement, particularly in lieu of a Performance Bond.

- b. Any Bidder shall furnish any data and information requested by the City Commission in its attempt to determine the ability of the Bidder to perform his/her obligations under the Contract.

1.0.12 TIME FOR RECEIVED BIDS - Bids received prior to the advertised hour of opening will be kept securely sealed. The official whose duty it is to open the Bids will decide when the specified time has arrived, and no Bid received thereafter will be considered.

1.0.13 WITHDRAWAL OF BIDS - Bids may be withdrawn on written or telegraphic request dispatched by the Bidder in time for delivery in the normal course of business prior to the time fixed for opening; provided that written confirmation of any telegraphic withdrawal over the signature of the Bidder is placed in the mail and post-marked prior to the time set for Bid opening.

1.0.14 OPENING OF BIDS - At the time and place fixed for the opening of Bids, the City Clerk will cause to be opened and publicly read aloud every Bid received within the time set for receiving Bids, irrespective of any irregularities therein. Bidders and other persons properly interested may be present in person or by representative.

1.0.15 AWARD OF CONTRACT - If the Contract is awarded, it will be awarded to the responsible Bidder submitting the lowest Bid complying with the conditions set forth in these Documents. The successful Bidder will be notified at the earliest possible date.

1.0.16 REJECTION OF BIDS; CITY'S RIGHTS

- a. The City Commission reserves the right to reject any and all Bids, and to waive any informality in Bids received, whenever such rejection or waiver is in its own best interest.
- b. The City Commission may consider as irregular and reject any Bid on which there is an alteration.
- c. The City Commission shall have the right to take such steps as it deems necessary to determine the ability of the Bidder to perform his/her obligations under the Contract.
- d. The right is reserved to reject any Bid where an investigation of the available evidence and/or information provided does not satisfy the City Commission of the Bidder's capacity to carry out the terms of the Contract.

1.0.17 EXECUTION OF CONTRACT AGREEMENT; PERFORMANCE AND PAYMENT BONDS

- a. Subsequent to the award and within ten (10) days after the Documents have been presented for signature, the successful Bidder shall execute the Agreement and deliver the requested number of copies to the City of Muskegon.
- b. Execution of the Agreement will require completion of the work in accordance with the Contract in its entirety.
- c. Upon delivery of the executed Contract Documents, the successful Bidder shall furnish the requisite bonds, in the penal sum not less than the amount of the Contract as awarded, as security for the faithful performance of the Contract and of the payment of all persons, firms or corporations to whom the Bidder as Contractor may become legally indebted, except as provided in paragraph (e) below.
- d. Such bonds shall be completed in accordance with the Instructions in Part 1 Section 2, and shall bear the same date as, or a date subsequent to, that of the Agreement.  
The surety bond shall be signed by a guaranty or the surety company listed in the latest issue of the U.S. Treasury Circ. 570, and the penal sum shall be within the maximum specified for such company in said Circular.
- e. In cases where this Contract is \$50,000 OR LESS and the successful Bidder is unable to, or chooses not to, provide the appropriate Performance Bonds, the Bidder may submit four letters of sincere

recommendation as to his/her prior performance to the City Manager for consideration in lieu of a Performance Bond, in basically the form described in Part 2 of these Documents.

This action must be taken prior to the execution of the Contract Agreement and the four letters must be accompanied by a statement from the Bidder, which contains the minimum requirements indicated for "Statement of Bidder's Qualifications". Upon City Manager and/or City Commission acceptance of the letters in lieu of the Performance Bond, the Contract Agreement shall be so executed.

- f. Failure of the successful Bidder to execute such number of Contract Documents as requested, to supply the required bonds or letters of recommendation with the Bidder's statement, and/or to meet the prescribed time limits, shall constitute a default.
- g. Upon such default, the City Commission may either award the Contract to the next lowest responsible bidder or re-advertise for bids.

The Commission may further charge against the defaulting Bidder the difference between the amount of his/her Bid and the amount for which a Contract for the work is subsequently executed, irrespective of whether the amount then exceeds the amount of the Bid Bond.

If a more favorable bid is received by re-advertising, the defaulting Bidder shall have no claim against the City of Muskegon.

1.0.18 COMMENCEMENT NOTICE TO PROCEED - The Contractor shall commence work only upon delivery of a Notice to Proceed from the City. In the event the said notice is not delivered within ten (10) days of the date of this agreement, then the dates for completion and any other performance dates shall be adjusted without further agreement so that the performance and completion dates shall be delayed the number of days in excess of ten (10) after the execution of the contract during which the City did not deliver the notice.



**SECTION 2 - BID PROPOSAL**

1.1 CONTRACT BIDDER'S CHECKLIST

THIS FORM IS A REFERENCE TOOL FOR BIDDING CONTRACTORS

The following forms ***MUST*** be completed:

	Completed?	
	Yes	No
1. Transmittal Letter for Bid Proposal (must acknowledge addenda received)		
2. Bidder Certification and Agreement		
3. Management Plans Questionnaire		
4. Bid Proposal		
5. Bid Bond (must be 5% of total bid)		
6. Non-Collusion Affidavit of Prime Bidder		
7. List of Proposed Sub-Contractors (if applicable)		
8. Disadvantaged Contractor Affidavit (if applicable)		
9. Statement of Bidders Qualifications (if applicable)		
10. Bid Tabulation Spreadsheet(s)		

Actual Completion of All Required Forms is the **Sole Responsibility of the Bidder**

---

---

**FAILURE TO COMPLETE THE NECESSARY FORMS MAY RESULT IN BID REJECTION**

---

---

1.2 TRANSMITTAL LETTER FOR BID PROPOSAL

**Bidder/Company Name** \_\_\_\_\_

**Name & Title of Head of Company** \_\_\_\_\_

**Street Address** \_\_\_\_\_

**City, State, ZIP** \_\_\_\_\_

**Phone Number/Email** \_\_\_\_\_

**Date** \_\_\_\_\_

**CITY OF MUSKEGON, MICHIGAN  
933 TERRACE ST.  
MUSKEGON, MI 49443-0536**

**PROJECT NO. WFP-22-001.**

**PROJECT NAME: : Roberts Street Tank Exterior, Dry Interior Painting, and Wet Interior Spot Painting WFP-22-001.**

Dear Awarding Agent,

Having examined the Bid Specifications and Contract Documents, including all forms and instructions, and the site of the proposed work, and being familiar with all of the conditions surrounding the construction of the proposed project, including the availability of materials and labor, and having received and reviewed the following Addenda:

\_\_\_\_\_  
\_\_\_\_\_

I/We hereby propose to furnish all labor, materials and supplies, and to construct the project in accordance with the Contract Documents and at the prices indicated in the attached Bid Proposal. Submitted prices are to cover all expenses incurred in performing the work required under the Contract Document, of which this letter and attached Proposal are a part.

In accordance with the Instructions to Bidders, all appropriate documents, forms, etc., have been properly completed and are attached hereto, along with the Bidder Certification and Agreement, List of Subcontractors, Non-Collusion Affidavits, and the proper Bid Guaranty.

I/We hereby respectfully submit the attached Bid Proposal for consideration by the City of Muskegon on the above-referenced Project.

\_\_\_\_\_  
Signature of Bidder/Representative

\_\_\_\_\_  
Printed Name and Title

1.3 BIDDER CERTIFICATION AND AGREEMENT

PART I.

The Undersigned hereby agrees:

That he/she has examined the Bid Specifications/Contract Documents, including specifications, forms and instructions;

That he/she has received and reviewed the following Addenda:

---

---

---

That he/she has examined the Site of the proposed work and is familiar with all of the conditions surrounding the construction of the proposed project and the availability of materials and labor.

PART II.

The Undersigned hereby agrees:

That he/she will enter into a contract to furnish the labor, materials, tools and construction equipment necessary for the full and complete execution of the work at and for the prices indicated in his/her official Bid Proposal, if said Proposal is accepted by the City;

That, at the time of execution of said Contract, he/she will furnish requisite bonds with such sureties (or letters of recommendation accompanied by a Bidder's Statement) for the faithful performance of the Contract, for the payment of all materials used therein, and for all labor expended thereon in accordance with the forms and instructions provided;

That he/she will construct the project in accordance with the Contract Documents within the specified time.

PART III.

The Undersigned hereby agrees:

**PROJECT SCHEDULE / DEADLINES**

**To commence work on or after June 1, 2022**  
**Substantial Completion by July 30, 2022 including cure and disinfection time.**  
**The tank may be out-of-service a maximum of 40 days.**

To comply with all applicable Adopted Guidelines and requirements, wage rates, labor standards, equal opportunity requirements, subcontract (or) requirements, and any other specifications indicated or referred to within these Contract Documents.

The Undersigned herewith attaches an Affidavit in proof that he/she has not entered into a collusive agreement with any person in respect to this Bid or any other bid, or the submitting of bids for the Contract for which this Bid is submitted.

The Undersigned is prepared to submit a Statement of Bidder's Qualifications, a financial statement, and/or any information requested by the City.

However, once work has commenced the project shall be completed without interruption of normal working days unless authorized in writing by the Engineer.

**PART IV**

In regard to non-segregated facilities, the Undersigned certifies:

That he/she does not maintain or provide for any employees any segregated facilities at any of his/her establishments;

That he/she does not permit employees to perform their services at any location, under his/her control, where segregated facilities are maintained;

That he/she will not maintain or provide for employees any segregated facilities at any of his/her establishments, and that he/she will not permit employees to perform their services at any location under his/her control where segregated facilities are maintained.

The Undersigned hereby agrees:

That a breach of this section of the Bidders Certification will be a violation of the Equal Opportunity clause in any contract resulting from acceptance of this Bid.

**That he/she will obtain identical certification from proposed sub-contractors prior to the award of subcontracts exceeding \$10,000 which are not exempt from the provisions of the Equal Opportunity clause (unless already obtained for specific time periods), and that he/she will retain such certifications on file.**

[As used in this section of this Bidder Certification, the term "segregated facilities" means any waiting rooms, work areas, restrooms, and washrooms, restaurants and other eating areas, time clocks, locker rooms and other storage or dressing areas, parking lots, drinking fountains, recreation or entertainment areas, transportation and housing facilities provided for employees which are segregated by explicit directive or are in fact segregated on the basis of race, color, religion or national origin, because of habit, local custom, or otherwise.]

NOTE: The penalty for making false statements in offers is prescribed in 18 U.S.C. 1001.

SIGNED: \_\_\_\_\_ DATED: \_\_\_\_\_

\_\_\_\_\_  
(Printed name)

\_\_\_\_\_  
(Title)

\_\_\_\_\_  
(Company/Bidder)

\_\_\_\_\_  
(Company/Bidder Street Address)

\_\_\_\_\_  
(Company/Bidder City, State Zip)

1.4 BID BOND

KNOW ALL MEN BY THESE PRESENTS, that we the undersigned,

\_\_\_\_\_ as PRINCIPAL, and  
(Name of Principal)

\_\_\_\_\_ as SURETY are held  
(Name of Surety)

and firmly bound unto the City of Muskegon, Michigan, in the penal sum of \_\_\_\_\_

\_\_\_\_\_ dollars, (\$ \_\_\_\_\_) lawful money of the United States, for the payment of which sum well and truly to be made, we bind ourselves, our heirs, executors, administrators, successors, and assigns, jointly and severally, firmly by these presents.

THE CONDITION OF THIS OBLIGATION IS SUCH, that whereas the Principal has submitted the Accompanying Bid, dated \_\_\_\_\_, 20\_\_\_\_\_, for \_\_\_\_\_.

NOW, THEREFORE, if the Principal shall not withdraw said Bid within the period specified for withdrawal; and shall within ten (10) days after the prescribed forms are presented for signature enter into a written Contract with the City of Muskegon in accordance with the Bid as accepted, and give bond with good and sufficient surety or sureties, as may be required for the faithful performance and proper fulfillment of such Contract; or

In the event of the withdrawal of said Bid within the period specified for withdrawal, or the failure to enter into such contract and give such bond within the time specified; and if the Principal shall pay the City of Muskegon the difference between the amount specified in said Bid and the amount for which the City of Muskegon may procure the required work or supplies or both, if the latter be in excess of the former.

THEN the above obligation shall be void and of no effect; otherwise shall remain in full force and virtue

IN WITNESS WHEREOF, the above-bounded parties have executed this instrument

Under their several seals this \_\_\_\_\_ day of \_\_\_\_\_, 20\_\_\_\_ the name and corporate seal of each corporate party being hereto affixed and these presents signed by its undersigned representative, pursuant to authority of its governing body.

In presence of

\_\_\_\_\_ (SEAL)  
(Individual Principal)

\_\_\_\_\_  
(Business Address including Zip Code)

\_\_\_\_\_  
(Partnership)

\_\_\_\_\_  
(Business Address including Zip Code)

Attest:

\_\_\_\_\_

By:

(SEAL)

\_\_\_\_\_  
(Corporate Principal)

\_\_\_\_\_  
(Business Address including Zip Code)

Attest:

\_\_\_\_\_

Affix  
Corporate  
Seal

Countersigned

By

Attorney-in-fact, State of \_\_\_\_\_

CERTIFICATE AS TO CORPORATE PRINCIPAL

I, \_\_\_\_\_, certify that I am the \_\_\_\_\_,

Secretary of the Corporation named as Principal in the within Bond; that

\_\_\_\_\_, who signed the said Bond on behalf of the Principal was then

\_\_\_\_\_ of said Corporation; that I know his/her signature, and his/her signature thereto is genuine; and that said bond was duly signed, sealed, and attested to for and in behalf of said Corporation by authority of this governing body.

Affix  
Corporate  
Seal

By: \_\_\_\_\_

Title: \_\_\_\_\_

1.5 NON-COLLUSION AFFIDAVIT OF PRIME BIDDER

State of \_\_\_\_\_ )  
 ) ss.  
County of \_\_\_\_\_ )

\_\_\_\_\_, being first duly sworn, deposes and says that:

1. He/She is \_\_\_\_\_  
(owner, partner, officer, representative, agent)  
of \_\_\_\_\_, the Bidder that has submitted the attached Bid to the City of Muskegon;
2. He/She is fully informed respecting the preparation and contents of the attached Bid and of all pertinent circumstances thereto;
3. Such Bid is genuine and is not a collusive or sham Bid;
4. Neither said Bidder nor any of his/her officers, partners, owners, agents, representatives, employees or parties in interest, including this affiant, has in any way colluded, conspired, connived or agreed, directly or indirectly, with any other Bidder, firm or person to submit a collusive or sham Bid in connection with the Contract for which the attached Bid has been submitted, or to refrain from bidding in connection with such Contract; nor has in any manner, directly or indirectly, sought by agreement, collusion, communication or conference with any other Bidder, firm or person to fix the price or prices in the attached Bid or any other bid; nor to fix any overhead, profit or cost element of the Bid price or the bid price of any other bidder; nor to secure through any collusion, conspiracy, connivance or unlawful agreement any advantage against the City of Muskegon or any person interested in the proposed Contract; and
5. The price or prices quoted in the attached Bid are fair and proper, and are not tainted by any collusion, conspiracy, connivance or unlawful agreement on the part of the Bidder or any part of its agents, representatives, owners, employees or parties in interest, including this affiant.

\_\_\_\_\_  
Signature

\_\_\_\_\_  
Printed Name and Title

Subscribed and sworn to before me

This \_\_\_\_\_ day of \_\_\_\_\_, 20\_\_\_\_

\_\_\_\_\_  
Title

My Commission expires \_\_\_\_\_



1.6 LIST OF PROPOSED SUB-CONTRACTORS

To be submitted by each Bidder with Bid Proposal in accordance with Para. 8, Part 1, Section 1. Before a subcontract is executed by the successful Bidder, the subcontractor must be approved by the City of Muskegon and the required documents executed in accordance with the Contract Documents.

1.	NAME OF FIRM	_____
	FIRM ADDRESS	_____
		_____
2.	NAME OF FIRM	_____
	FIRM ADDRESS	_____
		_____
3.	NAME OF FIRM	_____
	FIRM ADDRESS	_____
		_____
4.	NAME OF FIRM	_____
	FIRM ADDRESS	_____
		_____
5.	NAME OF FIRM	_____
	FIRM ADDRESS	_____
		_____
6.	NAME OF FIRM	_____
	FIRM ADDRESS	_____
		_____
7.	NAME OF FIRM	_____
	FIRM ADDRESS	_____
		_____

1.7 DISADVANTAGED CONTRACTOR AFFIDAVIT

Please provide the name(s) of all Disadvantaged subcontractors from whom you solicited bids for this project and additional information below.

Disadvantaged Contractor:	Contact Person:	Contact Method/Date:	Decision (Yes or No):
1. _____	_____	_____	_____
2. _____	_____	_____	_____
3. _____	_____	_____	_____
4. _____	_____	_____	_____

Of the Disadvantaged Contractors listed above, please indicate why they will not be used on this project.

Disadvantage Contractor:	Decision/Reason:
1. _____	_____ _____
2. _____	_____ _____
3. _____	_____ _____
4. _____	_____ _____

## 1.8 STATEMENT OF BIDDER'S QUALIFICATIONS

To be submitted by the Bidder upon specific request of City of Muskegon unless in connection with Letters of Recommendation in lieu of Performance Bond as provided in Section 1. The Statement of Bidder's Qualifications as follows must accompany the four Letters.

### 1.8.1 SUMMARY OF BIDDER'S INFORMATION TO BE PROVIDED

Each of the following items must be responded to in writing, and the information provided thereby must be clear and understandable. Upon completion, the Statement must be signed by the Bidder in front of a Notary Public and notarized. The Bidder may supply such additional information as desired after responding to each of these items:

1. NAME OF BIDDER (Company, individual, etc.)
2. PERMANENT MAIN OFFICE ADDRESS OF BUSINESS INCLUDING ZIP CODE.
3. DATE BUSINESS WAS ESTABLISHED.
4. IF A CORPORATION, WHERE WAS IT INCORPORATED?
5. NUMBER OF YEARS ENGAGED IN CONTRACTING BUSINESS UNDER PRESENT NAME?  
FIRM OR TRADE NAME? UNDER A PREVIOUS NAME?
6. SCHEDULE OF OUTSTANDING CONTRACTS, showing amount of each contract and the anticipated completion date of each.
7. GENERAL CHARACTER OF WORK PERFORMED BY YOUR COMPANY.
8. HAS THIS COMPANY EVER FAILED TO COMPLETE ANY WORK AWARDED IT?  
If so, WHERE AND WHY?
9. HAS THIS COMPANY EVER DEFAULTED ON A CONTRACT?  
If so, WHERE ANY WHY?
10. LIST THE PROJECTS RECENTLY COMPLETED BY YOUR COMPANY, stating approximate cost of each and the month/year completed. Indicate which, if any, have provided your company with a Letter of Recommendation.
11. INDICATE EXPERIENCE IN CONSTRUCTION WORK SIMILAR TO THIS PROJECT.
12. LIST YOUR MAJOR EQUIPMENT AVAILABLE FOR THIS CONTRACT.
13. INDICATE BACKGROUND AND EXPERIENCE OF THE PRINCIPAL MEMBERS OF YOUR ORGANIZATION, INCLUDING OFFICERS.
14. INDICATE CREDIT AVAILABLE TO YOUR COMPANY.
15. LIST BANK REFERENCES. If a detailed financial statement is available attach it to this statement.

16. ARE YOU WILLING TO COMPLETE A DETAILED FINANCIAL STATEMENT AND FURNISH ANY OTHER INFORMATION REQUIRED AND REQUESTED BY THE CITY OF MUSKEGON?

17. INCLUDE THE FOLLOWING STATEMENT: “The undersigned hereby authorizes and requests any person, firm or corporation to furnish any information requested by the City of Muskegon in verification of the recitals comprising this Statement of Bidder’s Qualifications.”

18. INCLUDE THE FOLLOWING AT THE END OF YOUR STATEMENT:

Dated this \_\_\_\_\_ day of \_\_\_\_\_, 20\_\_\_\_.

COMPANY/BIDDER NAME

SIGNATURE

PRINTED NAME AND TITLE OF PERSON SIGNING

19. INCLUDE OFFICIAL NAME AND DATA FOR NOTARY PUBLIC TO NOTARIZE DOCUMENT.

## 1.9 DBE/MBE/WBE PROCUREMENT POLICY

### 1.9.1 POLICY STATEMENT: 2014-31 (e)

It is the policy of the City of Muskegon to assure that small disadvantaged business enterprises (DBE), minority business enterprises (MBE), and woman-owned business enterprises (WBE) are given the opportunity to participate in contracting and procurement for supplies, construction, equipment and services under federal contracts and collaborations.

This policy applies to all contracts/procurement for supplies, construction equipment and services under any federally contracted grant or cooperative agreement. The purpose is to ensure nondiscrimination in the solicitation, either by competitive bidding or negotiation, and award and administration of federally assisted contracts and collaborations.

Entities contracting or sub-contracting with the City of Muskegon shall comply with regulations relative to nondiscrimination in Federally-assisted programs as amended from time to time (hereinafter referred to as the Regulations), which are herein incorporated by reference and made a part of this contract.

During the performance of any contract, the contractor, for itself, its assignees and successors in interest (hereinafter referred to as the “contractor”) agrees, as follows:

### 1.9.2 STATEMENT OF NON-DISCRIMINATION

The contractor, with regard to the work performed by it during the contract, shall not discriminate on the grounds of race, color, sex, or national origin in the selection, retention, and treatment of subcontractors, including procurements of supplies, construction, equipment and services.

### 1.9.3 FAIR SHARE GOALS

All methods of solicitation shall include the following language to meet “Good Faith Effort” requirements as stated in the general provisions of *EPA’s 40 CFR 33* of the Federal Regulation:

*This contract is subject to the Environmental Protection Agency’s (EPA) “fair share policy,” which includes EPA-approved “fair share goals” for Disadvantaged Business Enterprise (DBE), Minority Business Enterprise (MBE) and Woman Business Enterprise (WBE) firms in the Construction, Supplies, Equipment, and Services procurement categories. EPA’s policy requires that applicants and prime contractors make a good faith effort to award a fair share of contracts, subcontracts and procurements to Minority Business Enterprise and Women-Owned Business Enterprise firms. Although EPA’s policy does not mandate that the fair share goals be achieved, it does require applicants and prime contractors to demonstrate use of the six affirmative steps, and adhere to the current fair share goals for the State of Michigan.*

#### 1.9.4 GOOD FAITH EFFORTS

(1) The City of Muskegon shall ensure DBE/MBE/WBEs are made aware of contracting opportunities to the fullest extent practicable through outreach and recruitment activities by maintaining a solicitation list of DBE/MBE/WBE businesses and notifying them whenever they are potential sources.

(a) Maintain and update a listing of qualified DBE/MBE/WBEs that can be solicited for construction, equipment, services and/or supplies on the City of Muskegon website.

(b) Provide listings to all interested parties who request copies of the bidding or proposing documents.

(c) Contact appropriate sources within our geographic area to identify DBE/MBE/WBEs for placement on our business listings.

(d) Utilize other DBE/MBE/WBE listings such as those of the States Minority Business Office, the Small Business Administration, Minority Business Development Agency (MBDA) of the Department of Commerce, EPA OSDBU, DOJ, HUD, DOT and Department of Homeland Security.

(e) Solicitation lists are available for review at all times via the city website.

(2) The City of Muskegon shall make information of forthcoming opportunities available to DBE/MBE/WBEs and arrange time for viewing of contracts and establish delivery schedules, where requirements permit, in a way that encourages and facilitates participation by DBEs, MBEs, and WBEs in the competitive process. This includes, whenever possible, posting solicitations for bids or proposals for a minimum of 30 calendar days(federal projects) and 10 calendar days(local projects), before the bid or proposal closing date.

(a) Develop realistic delivery schedules which may provide for greater DBE/MBE/WBE participation.

(b) Advertise through the minority media in order to facilitate DBE/MBE/WBE utilization. Such advertisements may include, but are not limited to, contracting and subcontracting opportunities, hiring and employment, or any other matter related to the project.

(c) Advertise in general circulation publications, trade publications, State agency publications and minority and women's business focused media concerning contracting opportunities on our projects. Maintain a list of minority and/or women's business-focused publications that may be utilized to solicit DBE/MBE/WBEs.

(3) The City of Muskegon will consider in the contracting process whether firms competing for large contracts could subcontract with DBE/MBE/WBEs. The City of Muskegon will divide total requirements when economically feasible and practical into smaller tasks or quantities in order to increase opportunities for participation by DBE/MBE/WBEs in the competitive process.

(a) Perform an analysis to identify portions of work that can be divided and performed by qualified DBE/MBE/WBEs.

(b) Scrutinize the elements of the total project to develop economical units of work that are within the bonding range of DBE/MBE/WBEs.

(c) Conduct meetings, conferences, and follow-ups with DBE/MBE/WBE associations and minority media to inform these groups of opportunities to provide construction, equipment, services and supplies.

- (4) The City of Muskegon will consider and encourage contracting with a consortium of DBE/MBE/WBEs when a contract is too large for one of these firms to handle individually.
- (a) Notify DBE/MBE/WBEs of future procurement opportunities so they may establish bidding solicitations and procurement plans.
  - (b) Provide DBE/MBE/WBEs trade organizations with succinct summaries of solicitations.
  - (c) Provide interested DBE/MBE/WBEs with adequate information about plans, specifications, timing and other requirements of the proposed projects.
- (5) Use the services and assistance of the Small Business Administration (SBA) and the Minority Business Development Agency (MBDA).
- (a) Use the services of outreach programs sponsored by the MBDA and/or the SBA to recruit bona fide firms for placement on DBE/MBE/WBE bidder's lists to assist these firms in the development of bid packaging.
  - (b) Seek out Minority Business Development Centers (MBDCs) to assist recipients and prime contractors in identifying DBE/MBE/WBEs for potential work opportunities on projects
- (6) If the prime contractor awards subcontractors, the prime contractor is required to take the steps in subparagraphs (1)-(5) of this section.

#### 1.9.5 DOCUMENTATION/REPORTING

The contractor shall provide all information and reports required by the Regulations, or directives issues pursuant thereto, and shall permit access to its books, records, accounts, other sources of information, and its facilities as may be determined by the appropriate federal agency to be pertinent to ascertain compliance with such Regulations or directives. Where any information required of a contractor is in the exclusive possession of another who fails or refuses to furnish this information, the contractor shall so certify to the appropriate State or Federal Agency, as appropriate, and shall set forth what efforts it has made to obtain the information.

#### 1.9.6 NON – COMPLIANCE

Contractors, sub-contractors, and other associated entities failing to comply with the federal regulations legally required under contracts associated with Environmental Protection Agency (EPA), Housing and Urban Development (HUD), Department of Justice (DOJ), Department Of Transportation (DOT), or Department of Homeland Security (DHS) that have been granted to the City of Muskegon, may result in delayed closings, withholding the release of funds, or commitment cancellation.

### 1.10 BID TABULATION SPREADSHEETS

The Bid Tabulation spreadsheet(s) in these contract documents were created in Excel. Any Contractor who would like to use this spreadsheet in preparing a bid may obtain an electronic copy from the Engineering Office by calling the Engineering Department at (231)-724-6707.



**SECTION 00 54 00**  
**SCHEDULE OF VALUES**

**PART 1**

**1.01 LINE ITEMS**

A. Bidder agrees to perform all work in the following sections as described in the Contract Documents, including all labor and material for the following Schedule of Values – Section 03 00 00:

1. FOUNDATION SPALL REPAIR – 2 SQ. FT.  
\_\_\_\_\_ \$  
\_\_\_\_\_

B. Bidder agrees to perform all work in the following sections as described in the Contract Documents, including all labor and material for the following Schedule of Values – Section 05 00 00:

1. ROOF HATCH HASP  
\_\_\_\_\_ \$  
\_\_\_\_\_

2. OVERFLOW PIPE DISCHARGE MODIFICATION  
\_\_\_\_\_ \$  
\_\_\_\_\_

3. PAINTER’S RAILING STAND-OFFS  
\_\_\_\_\_ \$  
\_\_\_\_\_

4. WET INTERIOR PLATFORM PATCH PLATE  
\_\_\_\_\_ \$  
\_\_\_\_\_

5. OVERFLOW PIPE PENETRATION PATCH PLATE  
\_\_\_\_\_ \$  
\_\_\_\_\_

TOTAL PRICE SECTION 05 00 00 INCLUDING #1 THROUGH #5:  
\_\_\_\_\_ \$  
\_\_\_\_\_

C. Bidder agrees to perform all work in the following sections as described in the Contract Documents, including all labor and material for the following Schedule of Values – Section 09 00 00:

1. EXTERIOR OVERCOAT  
\_\_\_\_\_ \$  
\_\_\_\_\_

2. WET INTERIOR SPOT REPAINT  
\_\_\_\_\_ \$  
\_\_\_\_\_

3. DRY INTERIOR REPAINT  
\_\_\_\_\_ \$  
\_\_\_\_\_

4. LETTERING  
\_\_\_\_\_ \$  
\_\_\_\_\_

TOTAL PRICE SECTION 09 00 00 INCLUDING #1 THROUGH #4:  
\_\_\_\_\_ \$  
\_\_\_\_\_

D. Bidder agrees to perform all work in the following Sections as described in the Contract Documents, including all labor and material for the following Schedule of Values – Section 13 00 00:

1. MIXER  
\_\_\_\_\_ \$  
\_\_\_\_\_

E. Bidder agrees to perform all work in the following Sections as described in the Contract Documents, including all labor and material for the following Schedule of Values – Section 16 00 00:

1. LIGHT FIXTURE REPLACEMENT  
\_\_\_\_\_ \$  
\_\_\_\_\_

TOTAL PRICE SECTION 03 00 00, 05 00 00, 09 00 00, 13 00 00 and 16 00 00:

SECTION 03 00 00: \$ \_\_\_\_\_

SECTION 05 00 00: \$ \_\_\_\_\_

SECTION 09 00 00: \$ \_\_\_\_\_

SECTION 13 00 00: \$ \_\_\_\_\_

SECTION 16 00 00: \$ \_\_\_\_\_

PROJECT TOTAL: \$ \_\_\_\_\_

F. ESTIMATED COST ALREADY INCLUDED IN EXTERIOR AND DRY INTERIOR PAINTING TO PROTECT AND WORK AROUND ANTENNAS AND CABLES. OWNER RESERVES THE RIGHT TO DELETE THIS AMOUNT IF THE ANTENNAS AND CABLES ARE REMOVED.

\_\_\_\_\_ \$  
\_\_\_\_\_

## **1.02 TOTALS**

A. Project Total Base Bid is to match total Base Bid price supplied in Bid/Agreement form.

## **1.03 ALTERNATE BIDS**

A. Bidders are required to bid both Base and Alternate.

## **1.04 MISTAKES**

A. Project Total of Schedule of Values paragraph should equal sum of individual items.

If the addition of individual items does not match total, then each individual item will be added again and the math corrected.

B. A mistake in addition for schedule items cannot be used to increase lump sum bid. If Bid correction results in an increased price, then Owner may accept, may request Bidder to reduce all individual item prices proportionally, or may reject Bid.

C. Mistakes discovered after Award, even after completion will adjust Price downward only. It is the Contractor/Bidders responsibility to recheck prices prior to Award.

D. A mistake in Schedule of Values may be used as evidence of error in any request to withdraw bids because of error. Approval of request to withdraw bids is covered in the Information for Bidders. This section is not intended to conflict any portion of the bid package. Approval of bid withdrawal will be based solely on the Owner's interpretation of the severity of the mistake.

## **1.05 CHANGES in SCHEDULE of VALUES by OWNER**

A. The owner reserves the right to delete any line item of Part 1.01 adjusted line item; except for coating work, at their sole discretion for any reason. All contract general costs (mobilization, demobilization, bonds, etc.) should be evenly distributed over the coating items which are not subject to deletion.

B. The Bidder/Contractor is advised not to overload any specific deductible line item. It could result in loss of profit if the overload item is deleted.

C. This deletion of items or not including alternates is an expressly stated reservation (a contractually agreed automatic negotiation). Any deletion of specific line items will be completed before selection of the lowest responsible/responsive Bidder. Change will be reflected in the Notice of Award (NOA).

## **1.06 NON-DELETABLE WORK BEFORE and AFTER NOA**

A. Bidders are advised that all line items except for base bid coating work may be deleted from the project prior to award. Any deletion of line items, or increase or decrease in unit cost items deemed necessary after the Notice of Award, will be completed through the Change Order procedure. Prices used in the Schedule of Values will be used in the Change Order adjustment.

**PART 2 - AGREEMENT**

2.0 AWARDEE CHECKLIST

THIS FORM IS A REFERENCE TOOL FOR AWARDEE CONTRACTORS

The following forms **MUST** be completed:

	Completed?	
	Yes	No
1. Agreement (three signed copies)		
2. Performance Bond (three signed copies)		
3. Labor & Materialman's Bond (three signed copies)		
4. Non-Collusion Affidavit of Sub-Contractor (if applicable)		
5. Letters of Recommendation (if applicable)		
6. Certificate of Insurance (see requirements in section 3.0.24)		

Actual Completion of All Required Forms is the **Sole Responsibility of the Bidder**

---

---

**IMPORTANT: Please return three (3) original signed copies of each signed form**

---

---

## 2.1 DIRECTIONS FOR PREPARATION

1. Individual sureties, partnerships, or corporations not in the surety business will not be acceptable.
2. The name of the Principal shall be shown exactly as it appears in the Contract.
3. The penal sum shall not be less than that required by the Specifications.
4. If the Principals are partners, or joint ventures, each member shall execute the bond as an individual, with his/her place of residence shown.
5. If the Principal is a corporation, the bond shall be executed under its corporate seal. If the corporation has no corporate seal, the fact shall be stated, in which case a scroll or adhesive seal shall be affixed following the corporate name.
6. The official character and authority of the person(s) executing the bond for the Principal, if a corporation, shall be certified by the Secretary or Assistant Secretary thereof under the corporate seal; OR  
There may be attached copies of such corporation records as will evidence the official character and authority of the officer signing, duly certified by the Secretary or Assistant Secretary of the corporation, under the corporate seal, to be true copies.
7. The current Power-of-Attorney of the person signing for the surety company must be attached to the bond.
8. The date of the bond **MUST NOT BE PRIOR TO THE DATE OF THE CONTRACT.**
9. The following information must be placed on the bond by the surety company:
  - a. The rate of premium in dollars per thousand; and
  - b. The total dollar amount of the premium charged.
10. The signature of a witness shall appear in the appropriate place, attesting to the signature of each party to the bond.
11. Type or print the name underneath EACH SIGNATURE appearing on the bond.
12. An executed copy of the bond must be attached to each copy of the Contract (original counterpart) intended for signing.

2.2 AGREEMENT

THIS AGREEMENT, made this \_\_\_\_\_ day of \_\_\_\_\_, 20\_\_\_\_ \* by the City of Muskegon

And between \_\_\_\_\_

{ a corporation organized and existing under the laws of the state of MICHIGAN};

or [a partnership consisting of \_\_\_\_\_ ];

or [an individual trading as \_\_\_\_\_ ];

Hereinafter called the “Contractor”, and the CITY OF MUSKEGON, MICHIGAN:

WITNESSETH, that the Contractor and the City of Muskegon, for the consideration stated herein, mutually agree as follows:

ARTICLE 1. Statement of Work. The Contractor shall furnish all supervision, technical personnel, labor, materials, machinery, tools, equipment, and services, including utility and transportation services, and perform and complete all work required for the construction of the improvements embraced in this Contract, NAMELY:

***PROJECT DETAILS***

and required supplemental work for the completion of this Project, all in strict accordance with the Contract, including all Addenda.

ARTICLE 2. The Contract Price. The City of Muskegon will pay the Contractor for the performance of this Contract and the completion of the work covered therein an amount in current funds not to exceed \$\_\_\_\_\_.

ARTICLE 3. Contract. The executed contract shall consist of, but not be limited to, the following:

**Invitation for Bids**

**Part 1- Bids**

*Section 1 – Instruction to Bidders*

*Section 2 – Bid Proposal*

**Part 2 – Agreement**

**Part 3 – General Specifications**

*Section 1 – Project Performance*

*Section 2 – Affirmative Action*

*Section 3 – Labor Standards/EEOC/Anti-Kickback Act*

**Part 4 – Engineering Specifications**

**Part 5 – Project Special Specifications**

**Part 6 – MDOT Specifications**

**Part 7 – Appendices**

This Agreement, together with other documents enumerated in this Article 3, which said other documents are as fully part of the Contract as if attached hereto or repeated herein, form the Contract between the parties hereto.

In the event any provision in any component part of this Contract conflicts with any provision of any other component part, the Contractor shall contact the City immediately in writing for a determination, interpretation and/or clarification of conflicting parts and priority of same. Said determination from the City shall be in writing and shall become an Addendum to this Contract

*\*Date contract awarded by the City Commission*

IN WITNESS WHEREOF, the parties hereto have caused this AGREEMENT to be executed in  
**SIGNED, SEALED AND DELIVERED IN THREE (3) ORIGINAL COUNTERPARTS**

ATTEST:

CONTRACTOR

\_\_\_\_\_  
Signature

\_\_\_\_\_  
Signature

\_\_\_\_\_  
Printed Name and Title

ATTEST:

CITY OF MUSKEGON

\_\_\_\_\_  
Signature

\_\_\_\_\_  
**City of Muskegon Signature**

(SEAL)

CERTIFICATION (if applicable)

I, \_\_\_\_\_, certify that I am the \_\_\_\_\_ of the Corporation  
named as the Contractor herein;

That \_\_\_\_\_, who signed this Agreement on behalf of the Contractor, was then  
\_\_\_\_\_ of said Corporation;

That said Agreement was duly signed for and in behalf of said Corporation by authority of its governing body, and is  
within the scope of its corporate powers.

\_\_\_\_\_  
Signature

(CORPORATE SEAL)

\_\_\_\_\_  
Printed Name and Title



2.3 PERFORMANCE BOND

KNOW ALL MEN BY THESE PRESENTS, that we, \_\_\_\_\_  
\_\_\_\_\_  
as Principal, and \_\_\_\_\_,  
as Surety, are held and firmly bound unto the City of Muskegon, its certain attorney, successors or assigns  
(hereinafter called the Obligee), in the full and just sum of \_\_\_\_\_  
\_\_\_\_\_ dollars (\$ \_\_\_\_\_ ) lawful money  
of the United States, for the payment of which sum well and truly to be made, we bind ourselves, our heirs,  
administrators, executors, successors and assigns, jointly and severally, firmly by these presents:

WHEREAS, said Principal has entered into a certain contract with Obligee,  
Dated \_\_\_\_\_, 20\_\_\_\_, (hereinafter called the Contract) for: \_\_\_\_\_  
\_\_\_\_\_

and the specifications for said work shall be deemed a part hereof as fully as if set out herein:

NOW, THEREFORE, THE CONDITIONS OF THIS OBLIGATION ARE SUCH THAT:

- (a) If the Principal shall faithfully perform the Contract on his/her part, as of the time and in the manner therein provided; shall satisfy all claims and demands incurred in or for the same, or growing out of the same, or for injury or damages to persons or property in the performance thereof; shall fully indemnify and save harmless said Obligee from any and all cost and damage which the Obligee may suffer by reason of the Principal's failure to do so; and shall fully reimburse and par the Obligee any and all outlay and expense which it may occur by reason of such default; and
- (b) If, after completion and acceptance of the work by the Obligee, the Principal shall promptly remedy any defects in the work due to faulty materials or workmanship which shall appear within the period of one year from the date of completion and final acceptance of the work, and pay for any damage to said Obligee, to the State of Michigan, or to any municipal subdivision or local authority thereof to which the rights and privileges of said Obligee have passed or been assigned, then this obligation shall be null and void; otherwise it shall remain in full force and virtue.

The said Surety, for value received, hereby stipulates and agrees that no change, extension of time, alteration or addition to the terms of the Contract to the work to be performed thereunder, or to the specifications accompanying the same, shall in any wise affect its obligations on this Bond; and it does thereby waive notice of any such change, extension of time, alteration or addition to the terms of the Contract, or to the work or specifications.

It is hereby further stipulated and agreed that, if the Principal is a non-Michigan Corporation, neither the Principal nor the Surety shall be discharged from liability on this Bond, nor the bond surrendered, until such Principal files with the Obligee a certificate from the Michigan Department of Revenue evidencing the payment in full of all taxes, penalties and/or interest, and a certificate from the Unemployment Compensation Commission evidencing the payment of all unemployment compensation contributions, penalties and/or interest, due the State of Michigan from said Principal, or any non-Michigan corporation, subcontractor thereunder, or for which liability has accrued but the time for payment has not arrived.

**SIGNED, SEALED AND DELIVERED IN THREE (3) ORIGINAL COUNTERPARTS**

THIS \_\_\_\_\_ DAY OF \_\_\_\_\_, 20 \_\_\_\_\_.

Individual Principals Sign Here:

In the Presence of:

\_\_\_\_\_  
(SEAL)

\_\_\_\_\_

\_\_\_\_\_  
(SEAL)

\_\_\_\_\_

\_\_\_\_\_  
(SEAL)

\_\_\_\_\_

Corporate Principals Sign Here:

Attest:

\_\_\_\_\_

\_\_\_\_\_

\_\_\_\_\_  
(Printed Name and Title)

\_\_\_\_\_  
(Printed Name)

Surety Sign Here:

Attest:

\_\_\_\_\_

\_\_\_\_\_

\_\_\_\_\_  
(Printed Name and Title)

\_\_\_\_\_  
(Printed Name)

SEAL

The rate of premium charge is \$ \_\_\_\_\_ per thousand.

The total amount of premium charged is \$ \_\_\_\_\_  
(to be filled in by the Corporate Surety)

2.4 LABOR & MATERIALMAN'S BOND

KNOW ALL MEN BY THESE PRESENTS, that we, \_\_\_\_\_

\_\_\_\_\_ ,  
as Principal, and \_\_\_\_\_ ,

as Surety, are held and firmly bound unto the City of Muskegon, its certain attorney, successors or assigns (hereinafter called the Obligee) in the penal sum of \_\_\_\_\_ dollars (\$ \_\_\_\_\_ ) lawful money of the United States, for the payment of which sum well and truly to be made, we bind ourselves, our heirs, personal representatives, successors and assigns, jointly and severally, firmly by these presents:

WHEREAS, said Principal has entered into a certain contract with said Obligee, dated \_\_\_\_\_, 20\_\_\_\_, (hereinafter called the Contract) for: \_\_\_\_\_

\_\_\_\_\_ and the specifications for said work shall be deemed a part hereof as fully as if set out herein:

NOW, THEREFORE, THE CONDITION OF THIS OBLIGATION IS SUCH that, if said Principal, all subcontractors to whom any portion of the work provided for in said Contract is sublet, and all assignees of said Principal and of such subcontractors, shall promptly make payment for all material furnished, labor supplied or performed, rental for equipment employed and services rendered by public utilities in or in connection with the prosecution of the work, whether or not said material, labor, equipment or services entered into become component parts of the work or improvement contemplated in said Contract, in any amendment, extension of, or addition to said Contract, then the above obligation shall be void; otherwise, it shall remain in full force and effect; PROVIDED, HOWEVER, that this Bond is subject to the following conditions and limitations:

- (a) All persons who have performed labor, rendered services or furnished materials or equipment, shall have a direct right of action against the Principal and Surety on this Bond, which right of action shall be asserted in proceedings instituted in the State in which such labor was performed, services rendered or materials furnished (or where labor has been performed, services rendered or materials furnished under said Contract in more than one state, then in any such states). Insofar as permitted by the laws of such State, such right of action shall be asserted in a proceeding instituted in the name of the Obligee to the use and benefit of the persons instituting such action and any or all other persons having claims hereunder; and any other person having a claim hereunder shall have the right to be made a party to such proceedings, but not later than one year after the complete performance of said Contract and final settlement thereof, and to have such claim adjudicated in such action and judgment rendered thereon; PROVIDED HOWEVER, that the Obligee shall not be liable for the payment of any costs or expenses of any such suit.
- (b) The Surety shall not be liable hereunder for any damages or compensation recoverable under any workmen's compensation or employer's liability statute.
- (c) In no event shall the Surety be liable for a greater sum than the penalty of this Bond, or subject to any suit, action or proceeding thereon, that is instituted later than one year after the complete performance of said Contract and final settlement thereof.
- (d) As used herein: The term "Person" refers to any individual, firm or corporation which has furnished materials, equipment or public utility services to be used on or incorporated in the work, or the prosecution thereof, provided for in said Contract or any amendment, extension of, or addition to said Contract; and/or to any person engaged in the prosecution of the work provided for in said

Contract or any, extensions of, or addition to said Contract, who is an agent, servant or employee of the Principal or of any subcontractor, or any assignee of said Principal or any subcontractor; and also anyone so engaged who performs the work of a laborer or mechanic, regardless of any contractual relationship between the Principal or any subcontractor, or any assignee of said Principal or subcontractor and such laborer or mechanic; BUT shall not include office employees not regularly stationed at the site of the work.

- (e) It is hereby further stipulated and agreed that, if the Principal is a non-Michigan corporation, neither the Principal nor the Surety shall be discharged from liability on this Bond, nor the Bond surrendered, until such Principal files with the Obligee a certificate from the Michigan Department of Revenue evidencing the payment in full of all taxes, penalties and/or interest due the State of Michigan from the Principal, or any non-Michigan corporation, subcontractor thereunder, or for which liability has accrued but the time for payment has not arrived.

The Surety, for value received, hereby stipulates and agrees that no change, extension of time, alteration or addition to the terms of the Contract, to the work to be performed thereunder, or to the specifications accompanying the same, shall in any wise affect the obligations of this Bond, and it does hereby waive notice of any such change, extension of time, alteration or addition to the terms of the Contract, the work thereunder, or the specifications.

**SIGNED, SEALED AND DELIVERED IN THREE (3) ORIGINAL COUNTERPARTS**

THIS \_\_\_\_\_ DAY OF \_\_\_\_\_, 20 \_\_\_\_.

Individual Principals Sign Here:

In the Presence of:

\_\_\_\_\_

\_\_\_\_\_

(Printed Name and Address)

\_\_\_\_\_

\_\_\_\_\_

(Printed Name and Address)

\_\_\_\_\_

\_\_\_\_\_

(Printed Name and Address)

Corporate Principals Sign Here:

Attest:

\_\_\_\_\_

\_\_\_\_\_

(Printed Name and Title)

(Printed Name)

Surety Sign Here:

Attest:

\_\_\_\_\_

\_\_\_\_\_

(Printed Name and Title)

(Printed Name)

SEAL

2.5 NON-COLLUSION AFFIDAVIT OF SUBCONTRACTOR

State of \_\_\_\_\_ )  
 ) ss.  
County of \_\_\_\_\_ )

\_\_\_\_\_, being first duly sworn,  
deposes and says that:

1. He/She is \_\_\_\_\_  
(owner, partner, officer, representative, agent)  
of \_\_\_\_\_, the Bidder that has submitted the attached Bid to the City of Muskegon;
2. He/She is fully informed respecting the preparation and contents of the attached Bid and of all pertinent circumstances thereto;
3. Such Bid is genuine and is not a collusive or sham Bid;
4. Neither said Bidder nor any of his/her officers, partners, owners, agents, representatives, employees or parties in interest, including this affiant, has in any way colluded, conspired, connived or agreed, directly or indirectly, with any other Bidder, firm or person to submit a collusive or sham Bid in connection with the Contract for which the attached Bid has been submitted, or to refrain from bidding in connection with such Contract; nor has in any manner, directly or indirectly, sought by agreement, collusion, communication or conference with any other Bidder, firm or person to fix the price or prices in the attached Bid or any other bid; nor to fix any overhead, profit or cost element of the Bid price or the bid price of any other bidder; nor to secure through any collusion, conspiracy, connivance or unlawful agreement any advantage against the City of Muskegon or any person interested in the proposed Contract; and
5. The price or prices quoted in the attached Bid are fair and proper, and are not tainted by any collusion, conspiracy, connivance or unlawful agreement on the part of the Bidder or any part of its agents, representatives, owners, employees or parties in interest, including this affiant.

\_\_\_\_\_  
Signature

\_\_\_\_\_  
Printed Name and Title

Subscribed and sworn to before me

This \_\_\_\_\_ day of \_\_\_\_\_, 20\_\_\_\_\_

\_\_\_\_\_

\_\_\_\_\_  
Title

SEAL

## 2.6 LETTERS OF RECOMMENDATION IN LIEU OF PERFORMANCE BOND

In accordance with Section 1, four letters of sincere recommendation may be presented to the City Manager in lieu of a performance bond when this Contract is under the amount of \$50,000 and the successful Bidder cannot produce the appropriate performance bond.

To use letters of recommendation for this purpose, your intention to do so must be disclosed as part of your bid, so that a decision on acceptability can be made prior to the contract award.

The four letters are to be presented prior to the execution of the Contract Agreement and must be accompanied by the Statement of Bidder's Qualifications as outlined (Part 1, Section 2, Bid Proposal). Each of the four letters should contain no less than the following information:

<p>THE LETTER OF RECOMMENDATION PACKAGE IS SUBJECT TO CITY MANAGER AND/OR CITY COMMISSION APPROVAL PRIOR TO LETTING THE BID OR EXECUTING THE AGREEMENT.</p>
---

---

### SUMMARY OF INFORMATION TO BE INCLUDED IN EACH LETTER OF RECOMMENDATION

1. On letterhead of the recommending company, including name, address and phone number of the recommending company.
2. Include reference to the name of the company being recommended.
3. Include a brief description of the type of each of the projects the recommended company performed, the total dollars contracted for each, and the date of construction start and completion under each contract.
4. Include a statement indicating how the company being recommended performed the work involved under the contracts, whether the recommended company accomplished the work satisfactorily and within the appropriate time limits of the contracts.
5. Indicate if there was any default on the part of or litigation as a result of the recommended company.
6. Indicate if, to the best of knowledge, all subcontractors and/or suppliers of labor or materials on each project were properly compensated by the company being recommended.
7. Include a statement the same as, or similar to the following:  
  
"I, on behalf of my organization (or company by name) recommend this company (or the name of the company being recommended) as responsible and competent, and I believe they can capably perform construction work similar to that described in this letter in a timely and satisfactory manner."

**PART 3 – GENERAL SPECIFICATIONS**

## **SECTION 1**



GENERAL SPECIFICATIONS  
3.0 FOR PROJECT PERFORMANCE

3.0.1 ASSIGNMENT OR NOVATION

- a. The Contractor shall not assign or transfer, whether by an assignment or novation, any of its rights, duties, benefits, obligations, liabilities or responsibilities under this Contract without the written consent of the City of Muskegon; provided, however, that assignments to banks, trust companies or other financial institutions may be made without said consent.
- b. No assignment or novation of this Contract shall be valid unless it expressly provides that the assignment of any of the Contractor's rights or benefits under the Contract is subject to a prior lien for labor performed, services rendered, and materials, tools and equipment supplied for the performance of the work under this Contract in favor of all persons, firms or corporations rendering such labor or services, or supplying such materials, tools or equipment.

3.0.2 CONFLICT OF INTEREST

- a. No official of the City of Muskegon who is authorized in such capacity and on behalf of the City to negotiate, make, accept or approve, or to take part in negotiating, making, accepting or approving, any engineering, inspection, construction or material supply contract, or any subcontract, in connection with the construction of this Project shall become directly or indirectly interested personally in this Contract or in any part hereof.
- b. No officer, employee, architect, attorney, engineer or inspector of or for the City who is authorized in such capacity, and on behalf of the City, to exercise any legislative, executive, supervisory or other similar function in connection with the construction of this Project, shall become directly or indirectly interested personally in this Contract or in any part hereof, any material supply contract, any subcontract, any insurance contract, or any other contract pertaining to this Project.

3.0.3 CITY'S AUTHORITY

- a. The City of Muskegon shall designate and identify its Authorized Representative(s) and Inspectors.
- b. The Authorized Representative will be responsible for the execution of the work under this Contract. The Authorized Representative will determine the amount, quality, acceptability of materials, and fitness of the work to be paid for under this Contract. That Representative will decide all questions which may arise in relation to said work and the construction thereof. The City's estimates and decisions shall be final and conclusive, except as herein otherwise expressly provided.
- c. Inspectors will work under the direct supervision of the Authorized Representative. Inspectors will not be authorized to revoke, alter, enlarge or relax any of these specifications nor to change the plans in any particular. The Inspector on the work will inform the Authorized Representative as to the progress of the work, the manner in which it is being done, and the quality of the materials being used. He/She will also call to the attention of the Contractor any failure to follow the plans and specifications that may be observed. He/She shall have the authority to prevent any material from being used, and to stop any work from being done, which he/she believes does not conform to the plans and specifications, until the Authorized Representative has an opportunity to inspect the material or work. In no instance shall any action or omission on the part of the Inspector relieve the Contractor of the responsibility of completing the work in accordance with the plans and specifications.
- d. In case any question shall arise between the parties hereto relative to said Contract, the determination or decision of the City shall be a condition precedent to the right of the Contractor to receive any money or payment for work under this Contract affected in any manner, or to any extent, by such question.
- e. The City shall decide the meaning and intent of any portion of this Contract or any specifications therein where the same may be found obscure or in dispute. Any differences or conflicts in regard to the work which may arise between the Contractor under this Contract and other contractors performing work for the City shall be adjusted and determined by the City.

3.0.4 OTHER CONTRACTS - The City may award, or may have awarded, other contracts for additional work in the vicinity of this Project; and the Contractor shall cooperate fully with such other contractors by scheduling his/her own work with that to be performed under other contracts as may be directed by the City. The Contractor shall not commit or permit any act which will interfere with the performance of work by any other contractor as scheduled.

3.0.5 TERMINATION OF CONTRACT

- a. If the Contractor refuses or fails to prosecute the work with such diligence as will ensure its completion within the time specified, or as amended, in these Contract Documents, the City may, by written notice, terminate the Contractor's right to proceed with the work.
- b. Upon such termination, the City of Muskegon may take over the work and prosecute same to completion, by contract or otherwise, and may take possession of, and utilize in completing the work, such materials, tools, equipment and plant as may be on the site of the work and necessary to the completion thereof.
- c. The Contractor and the sureties to the Contract shall be liable to the City for any additional cost incurred by the City in its completion of the work, and shall further be liable for the liquidated damages for any delay in completion of work as provided by this Contract.

3.0.6 REVIEW BY AUTHORIZED REPRESENTATIVES - The City of Muskegon, its authorized representative(s) and/or agents shall at all times have access to, and be permitted to observe and review, all work, materials, equipment, payrolls, personnel records, employment conditions, material invoices, and other relevant data and records pertaining to this Contract, however, that all instructions and approval with respect to the work will be given to the Contractor by the City of Muskegon through its Authorized Representative.

3.0.7 GENERAL GUARANTY

- a. Final acceptance of the work will be acknowledged in writing to the Contractor by the City of Muskegon. Neither the final certificate of payment, any provision in the Contract, nor partial or entire use of the improvements embraced in this Contract by the City or the public shall constitute an acceptance of work not done in accordance with the Contract; nor shall such certificate, provision or use relieve the Contractor of liability in respect to any express warranties or responsibilities for faulty materials or workmanship.
- b. The period of guarantee shall not begin until the date of final written acceptance by the City of all work required. The Contractor shall promptly remedy any defects in the work and pay for the damage to other work resulting therefrom which shall appear within a period of twelve (12) months from the date of final acceptance of the work.

3.0.8 WARRANTY OF TITLE

- a. No material, supplies or equipment for the work shall be purchased subject to any chattel mortgage or under conditional sale or other agreement by which an interest therein, or in any part thereof, is retained by the seller or supplier.
- b. The Contractor shall warrant good title to all materials, supplies and equipment installed or incorporated in the work and, upon completion of all work, shall deliver the same, together with all improvements and appurtenances constructed or placed thereon by him/her, to the City of Muskegon free from any claims, liens or charges.
- c. Neither the Contractor nor any person, firm or corporation furnishing any material and/or labor for any work covered by this Contract shall have any right to a lien upon any improvement or appurtenance thereon.
- d. Nothing contained in this paragraph, however, shall impair:
  - i. The right of persons furnishing materials or labor to recover funds owed them under any bond given by the Contractor for their protection;
  - ii. Any rights under any law permitting such persons to look to funds due the Contractor yet in the hands of the City.
- e. The provisions of this Subsection 5 shall be inserted in all Subcontracts and material contracts; and notice of its provisions shall be given to all persons furnishing materials for the Project when no formal contract is entered into for such materials.

3.0.9 PATENTS - The Contractor shall hold and save the City of Muskegon, its officers and employees, harmless from liability of any nature or kind, including costs and expenses, for or on account of any patented or unpatented invention, process article, or appliance manufactured or used in the performance of the Contract, including its use by the City of Muskegon.

3.0.10 PAYROLLS AND BASIC RECORDS

- a. The Contractor will submit weekly a copy of all payrolls, basic records relating thereto, and completed forms as requested, to the City's Affirmative Action Department accompanied by a "Weekly Statement of Compliance". The prime Contractor shall be responsible for the submission of copies of payrolls of all Subcontractors. \*
- b. The Contractor shall submit to the City such schedule of quantities and costs, progress schedules, payrolls, reports, estimates, records and other data as the City may request from time to time concerning the work performed under this Contract.
- c. The Contractor shall withhold Muskegon City Income Taxes from each and every employee who is subject to same, and shall pay Contractor's Income Tax due, if any. Contractor shall further require the same of each Subcontractor, consultant or other pay with whom the contractor works or from whom contractor obtains goods or services for the project. Payroll submissions required by this agreement shall include full information showing said withholding. The City may withhold payments otherwise due to the contractor to assure compliance with this agreement or cure noncompliance.

3.0.11 SIGNS AS REQUIRED

- a. The signs that may be required for this project by the Department of HUD, the National Historic Preservation organizations, or other pertinent funding agencies which may require significant posting on the job site, will be provided and erected by the Contractor as incidental to the Contract.
- b. The Contractor shall maintain these signs in good condition throughout the life of this contract.

3.0.12 NATIONAL HISTORIC PRESERVATION ACT OF 1966 - The Contractor agrees to contribute to the preservation and enhancement of structures and objects of historical, architectural or archaeological significance when such items are found and/or unearthed during the course of the project, and to consult with the State Historic Preservation Officer for recovery of the items: [Reference: National Historic Preservation Act of 1966 (80 Stat 915, 16 USC 470) and Executive Order No. 11593 of May 31, 1971] AND to assure Subcontractor's compliance as well.

3.0.13 CLEAN AIR ACT - The Contractor shall comply and shall require each of its Subcontractors employed in the completion of this project to comply with all applicable provisions of the Clean Air Act as amended by Public Law 91-604.\*

3.0.14 SOIL EROSION AND SEDIMENT CONTROL ACTS

- a. Public Acts 346 and 347 as amended shall be observed and enforced while working under these documents. Necessary permits for both Acts shall be obtained by the City of Muskegon. Enforcement for Act 346 shall be by the Michigan Department of Natural Resources, and the enforcing agent for Act 347 shall be the City of Muskegon.
- b. The Contractor shall conduct his/her work in such a manner that soil, fuels, oil, bituminous materials, chemicals, sanitary sewage and other harmful materials resulting from the execution of this project are confined within project limits and prevented from entering watercourses, rivers, lakes or reservoirs. All applicable regulations of fish and wildlife agencies and statutes relating to the prevention and abatement of pollution shall be complied with during the performance of this contract. Operations shall be conducted in such a manner as to reduce erosion to the practicable minimum to prevent damaging sedimentation of watercourses, streams or lakes.\*
- c. The Contractor shall be responsible for utilizing various measures of control in his/her own work and that of Subcontractors to prevent erosion and sediment damage. When applicable, these measures and requirements will be identified and provided on the plans or in the Special Specifications. They are, however, not to be considered all-inclusive, as additional protective measures may be required as the work progresses. No payment will be allowed for this work.

3.0.15 SOIL REMOVAL AND DUMPING ORDINANCE - Under City ordinance, a permit must be obtained from, and a \$150 fee paid to, the City of Muskegon Building Inspection Department IF excavated or excess soil materials become the property of the Contractor AND those materials are to be deposited as fill within the corporate limits of the City of Muskegon; OTHERWISE, no permit will be required of the Contractor while working on the Project covered by this Contract.

3.0.16 PERMITS AND CODES

- a. The Contractor shall give all notices required by and comply with all applicable laws, ordinances and codes of the local government. All construction work and/or utility installations shall comply with all applicable ordinances and codes including all written waivers. Before installing any work, the Contractor shall examine the drawings and the Specifications for compliance with applicable ordinances and codes, and shall immediately report any discrepancy to the City.
- b. Where the requirements of the drawings and Specifications fail to comply with such applicable ordinances and codes, the City will adjust the Contract by Change Order to conform to such ordinances or codes (unless waivers in writing covering the difference have been granted by the governing body or department) and make appropriate adjustment in the Contract Price or stipulated Unit Prices.
- c. Should the Contractor fail to observe the foregoing provisions and proceed with the construction and/or install any utility at variance with any applicable ordinance or code, including any written waivers (notwithstanding the fact that such installation is in compliance with drawings, Technical or Special Specifications), the Contractor shall remove such work without cost to the City, but a Change Order may be issued to cover only the excess cost the Contractor would have been entitled to receive if the change had been made before he/she commenced work on the items involved.
- d. The Contractor shall at his/her own expense secure and pay for all necessary permits to execute the work from each involved governmental unit, whether it be the City of Muskegon, townships, County or State of Michigan. In some cases, certain permits will be obtained by the owner and will be so identified within the Special Specifications. All other permits are the responsibility of the Contractor.
- e. The Contractor shall comply with applicable local and state laws and ordinances governing the disposal of surplus excavation materials, debris and rubbish on or off the Project Site and commit to trespass on any public or private property in any operation due to or connected with the improvements embraced in this Contract.

3.0.17 TRAFFIC CONTROL - The Contractor shall at all time so conduct his/her work as to ensure the least possible obstruction to traffic. The safety and convenience of the general public and the residents in or adjacent to the Project Site and the protection of persons and property shall be provided for by the Contractor. The Contractor shall provide and maintain adequate barricades, signs, lights and flags to warn and guide the public, and shall provide flagmen and watchmen when needed or when so ordered by the City in full accordance with the MICHIGAN MANUAL OF UNIFORM TRAFFIC ONTROL DEVICES, published and revised from time to time by the Michigan Department of Transportation. The Contractor shall be responsible for compliance with this Item by all Subcontractors as well.\*

3.0.18 REQUIRED PROVISIONS DEEMED INSERTED - Each and every provision of law and clause required by law to be inserted in this Contract shall be deemed to be inserted herein, and the Contract shall be read and enforced as though it were included herein; and, if through error or otherwise, any such provision is not inserted, or is incorrectly inserted, then upon the application of either party to this Contract, the Contract shall forthwith be physically amended to make such insertion or correction. This clause shall be included in all Subcontracts.\*

3.0.19 COMMUNICATIONS

- a. All notices, demands, requests, instructions, approvals, proposals and claims must be in writing.
- b. Any notice to or demand upon the Contractor from the City relative to any part of this Contract shall be sufficiently considered given, and the service thereof completed, when said notice is posted, by certified or registered mail, to the Contractor at his/her last given address; or when said notice is delivered in person to the Contractor or authorized representative on the Project Site, at the office

of the Contractor, or to any telegraph company for transmission with charges prepaid, in each case addressed to such office.

- c. All papers required to be delivered to the City of Muskegon shall be delivered to the Muskegon City Hall, to the attention of the Authorized Representative on this Project, and any notice to or demand upon the City shall be sufficiently given if so delivered, or if posted, by certified or registered mail, to 933 Terrace Street, Muskegon, Michigan 49443, or to any telegraph company for transmission with charges prepaid, in each case to the same address. Any such notice shall be deemed to have been given as of the time of the actual delivery or at the time of actual receipt, as the case may be.

3.0.20 REQUEST FOR SUPPLEMENTARY INFORMATION - It shall be the responsibility of the Contractor to make timely requests of the City for any additional information not already in his/her possession which should be furnished by the City under the terms of this Contract, and which he/she will require in the planning and execution of the work. Such requests may be submitted from time to time as the need arises, but each shall be filed in ample time to permit appropriate action to be taken by all parties involved so as to avoid delay. Each request shall be in writing, listing the various items and the latest date by which each will be required by the Contractor. The first list shall be submitted within two (2) weeks after the Contract award, and shall be as complete as possible at that time. The Contractor shall, upon request, furnish promptly any assistance and information the City may require in responding to these requests. The Contractor shall be fully responsible for any delay in his/her work or to others arising from his/her failure to comply fully with the provision of this Article.

#### 3.0.21 PROGRESS SCHEDULE AND NOTIFICATION REQUIREMENTS

- a. Immediately after execution of the Agreement, the Contractor shall submit for approval a carefully prepared Progress Schedule showing the proposed dates of starting and completing each of the various sections of work. The work which the Contractor is required to perform under this Contract shall commence at the time stipulated by the City in its Notice to Proceed and shall be fully completed by the dates indicated in the Contract Agreement.
- b. The Contractor shall notify the City's Authorized Representative as to the exact time at which he/she proposes to begin any part of the work at least 48 hours in advance of any such start so that line and grade can be established and inspections provided.
- c. When work is to be done by City forces, in coordination with City forces, or if City of Muskegon utilities need to be located and/or marked, the Contractor shall provide at least 48 hours' advance notice to the City Department from which the work is requested.
- d. The Contractor shall notify "Miss Dig" 48 hours in advance of any work start to allow sufficient time for utility identification and location. The City of Muskegon is NOT a part of the "Miss Dig" program.
- e. Before permission can be granted by the Authorized Representative for street closures, it shall be the Contractor's responsibility to notify the police and fire departments and the Department of Public Works and Utilities.

#### 3.0.22 PAYMENTS BY THE CONTRACTOR

- a. The Contractor shall provide and pay for all materials, labor, tools, equipment, water, lights, heat, power, transportation, superintendence, temporary construction of every nature, charges, levies, fees or other expenses, and all other services and facilities of every nature necessary for the performance of this Contract and delivery of all improvements embraced therein within the specified time.
- b. The Contractor shall pay for all transportation and utility services not later than the 20th day of the calendar month following that in which services are rendered.
- c. The Contractor shall pay for all materials, tools, and other expendable equipment to the extent of 90% of the cost thereof, not later than the 20th day of the calendar month following that in which such materials, tools and equipment are delivered at the Project Site, and the balance of cost thereof not later than the 30th day following the completion of that part of the work in or on which such materials, tools and equipment are incorporated or used.
- d. The Contractor shall pay to each of his/her Subcontractors, not later than the 5th day following each payment to the Contractor, the respective amounts allowed him/her on account of the work performed by the Subcontractors to the extent of each Subcontractor's interest therein.

### 3.0.23 SUBCONTRACTS

- a. The Contractor shall not execute an agreement with any Subcontractor or permit any subcontractor to perform any work included in this Contract until he/she has submitted a non-collusive affidavit from the subcontractor and received written approval of such subcontractor from the City of Muskegon.
- b. The Contractor shall be as fully responsible to the City of Muskegon for the acts and omissions of his/her Subcontractors, and of persons either directly or indirectly employed by them, as he/she is for the acts and omissions of persons directly employed by the Contractor.
- c. The Contractor shall cause appropriate provisions to be inserted in all Sub-contracts relative to compliance by each Sub- contractor with the provisions of this Contract.
- d. No proposed Subcontractor shall be disapproved by the City of Muskegon except for cause. Nothing contained in this Contract shall create any contractual relation between any Subcontractor and the City of Muskegon.

### 3.0.24 INSURANCE AND INDEMNITY

- a. Hold Harmless Agreements. To the fullest extent permitted by law, Contractor and Subcontractors agree to defend, pay in behalf of, indemnify, and hold harmless the CITY OF MUSKEGON, all elected and appointed officials, all employees and volunteers, all boards, commissions, and/or authorities and board members, including employees and volunteers thereof working on behalf of the CITY OF MUSKEGON against any and all claims, demands, suits, or loss, including all costs connected therewith, and for any damages which may be asserted, claimed or recovered against or from the CITY OF MUSKEGON and their elected and appointed officials, employees, volunteers, or others working on behalf of the CITY OF MUSKEGON by reason of personal injury, including bodily injury and death, property damage, including loss of use thereof, and/or the effects of or release of toxic and/or hazardous material which arises out of or is any way connected or associated with this contract. The obligation to defend and hold harmless extends to Contractor's employees, agents, subcontractors, assigns and successors.
- b. The Contractor, and any and all of their subcontractors, shall not commence work under this contract until they have obtained the insurance required under this paragraph, and shall keep such insurance in force during the entire life of this contract. All coverage shall be with insurance companies licensed and admitted to do business in the State of Michigan and acceptable to CITY OF MUSKEGON. The requirements below should not be interpreted to limit the liability of the Contractor. All deductibles and SIRs are the responsibility of the Contractor.
- c. **The Contractor shall procure and maintain the following insurance coverage:**
  - i. **Workers' Compensation Insurance**, including Employers' Liability Coverage, in accordance with all applicable statutes of the State of Michigan.
  - ii. **Commercial General Liability Insurance** on an "Occurrence Basis" with limits of liability not less than \$3,000,000 per occurrence and aggregate. Coverage shall include, but not limited to, the following: (A) Contractual Liability; (B) Products and Completed Operations; (C) Independent Contractors Coverage; (D) Broad Form General Liability Extensions or equivalent; (E) Explosion, Collapse, and Underground, if applicable.
  - iii. **Automobile Liability**, including Michigan No-Fault Coverages, with limits of liability not less than \$1,000,000 per occurrence combined single limit for Bodily Injury, and Property Damage. Coverage shall include all owned vehicles, all non-owned vehicles, and all hired vehicles.
  - iv. Commercial General Liability and Automobile Liability Required liability limits may be obtained by using an Excess/Umbrella Liability policy in addition to the primary liability policy(ies). If coverage limits are satisfied by an Excess and/or Umbrella policy, coverage must follow form of the primary liability policy(ies), including but not limited to additional insured and primary/non-contributory coverage.
  - v. **Additional Insured:** Commercial General Liability Insurance shall include an

endorsement stating the following shall be ***Additional Insureds***: The CITY OF MUSKEGON, all elected and appointed officials, all employees and volunteers, agents, all boards, commissions, and/or authorities and board members, including employees and volunteers thereof. It is understood and agreed by naming the CITY OF MUSKEGON as additional insured, coverage afforded is primary and any other insurance the CITY OF MUSKEGON may have in effect shall be secondary and/or excess.

- vi. **Owners' and Contractors' Protective Liability**: A separate Owners' and Contractors' Protective Liability Policy with limits of liability not less than \$1,000,000 per occurrence and aggregate. The CITY OF MUSKEGON shall be "Named Insured" on said coverage. Said insurance shall cover liability caused by activities of any subcontractor(s) either by means of a rider attached to the Prime Contractor's Certificate of Insurance indicating this coverage for subcontractors; or the subcontractor(s) shall submit their own Certificate of Insurance.
- vii. **Cancellation Notice**: Policy(ies), as described above, shall be endorsed to state the following: It is understood and agreed Thirty (30) days, Ten (10) days for non-payment of premium, Advance Written Notice of Cancellation or Non-Renewal shall be sent to the Certificate Holder: (CITY OF MUSKEGON ENGINEERING DEPARTMENT, PO Box 0536, Muskegon, MI 49443-0536)
- viii. The Contractor shall provide the CITY OF MUSKEGON at the time the contracts are returned by him/her for execution a Certificate of Insurance as well as the required endorsements. In lieu of required endorsements, a copy of the policy sections, where coverage is provided for additional insured and cancellation notice, may be acceptable. Copies of all policies mentioned above shall be furnished, if so requested.
- ix. If any of the above coverages expire during the term of this contract, the Contractor shall deliver renewal certificates, endorsements, and/or policies to CITY OF MUSKEGON at least ten (10) days prior to the expiration date.

### 3.0.25 MATERIALS AND WORKMANSHIP

- a. Unless otherwise specifically provided for in the Technical or Special Specifications, all workmanship, equipment, materials and articles the work shall be new and the best grade of the respective kinds for the purpose. Where equipment, materials, articles or workmanship are referred to as "equal to" any particular standard, the City of Muskegon will decide the question of equality.
- b. The City of Muskegon may require the Contractor to dismiss from this Project such employee(s) as the City of Muskegon may deem incompetent, careless, and/or insubordinate.

### 3.0.26 SUPERINTENDENCE BY CONTRACTOR

- a. Except where the Contractor is an individual and gives his/her personal superintendence to the work, the Contractor shall provide a competent superintendent, satisfactory to the City of Muskegon, on the work at all times during working hours with full authority to act for the Contractor. The Contractor shall also provide adequate staff for the proper coordination and expediting of the work.
- b. The Contractor shall lay out his/her own work, and shall be responsible for all work executed by him/her under this Contract. He/She shall verify all figures and elevations before proceeding with the work and will be held responsible for any error resulting from his/her failure to do so.

3.0.27 FITTING AND COORDINATION OF THE WORK - The Contractor shall be responsible for the proper fitting of all work, and for the coordination of the operations of all trades, subcontractors, or materialmen engaged upon this Contract. He/She shall be prepared to guarantee to each of his/her Subcontractors the locations and measurements which they may require for the fitting of their work to all surrounding work.

### 3.0.28 MUTUAL RESPONSIBILITY OF CONTRACTORS

- a. If, through acts or neglect on the part of the Contractor, any other contractor or any subcontractor shall suffer loss or damage on the work, the Contractor shall settle with such other contractor or subcontractor by agreement or arbitration, if such other contractor or subcontractor will so settle.
- b. If such other contractor or subcontractor shall assert any claim against the City of Muskegon on account of any damage alleged to have been so sustained, the City will notify the Contractor, who

shall defend at his/her own expense any suit based upon such claim, and, if any judgment or claim against the City is allowed, the Contractor shall pay all costs and expenses in connection therewith.

### 3.0.29 CARE OF THE WORK

- a. The Contractor shall be responsible for all damages to person or property that occur as a result of his/her fault or negligence in connection with the prosecution of the work and shall be responsible for the proper care and protection of all materials delivered and work performed until completion and final acceptance, whether or not the same has been covered in whole or part by payments made by the City.
- b. The Contractor shall provide sufficient competent watchmen, both day and night, including Saturdays, Sundays and holidays, from the time the work commences until final completion and acceptance, as needed.
- c. In an emergency affecting the safety of life, limb or property, including adjoining property, the Contractor, without special instructions or authorization from the City, is authorized to act at his/her own discretion to prevent such threatened loss or injury, and he/she shall so act. He/She shall likewise act if instructed to do so by the City. Any compensation claimed by the Contractor on account of such emergency work will be determined by the City as provided in this Contract regarding Change Orders.
- d. The Contractor shall avoid damage as a result of his/her operation to existing sidewalks, streets, curbs, pavements, utilities (except those which are to be replaced or removed), adjoining property, etc., and he/she shall at his/her own expense completely repair any damage thereto caused by his/her operation.
- e. The Contractor shall shore up, brace, underpin, secure and protect, as may be necessary, all foundations and other parts of existing structures adjacent to, adjoining, and in the vicinity of, the Site which may be in any way affected by the excavations or other operations connected with the execution of this Contract. The Contractor shall be responsible for the giving of any and all required notices to any adjoining or adjacent property owner or other party before commencement of any work. The Contractor shall indemnify and save harmless the City of Muskegon from the damages on account of settlements or the loss of lateral support of adjoining property and from all loss or expense and all damages for which the City may become liable in consequence of such injury or damage to adjoining and adjacent structures and their premises.

### 3.0.30 SURVEY MONUMENTS

- a. Survey monuments relative to governmental surveys such as a U.S. Coast and Geodetic and the City of Muskegon datum plane reference are to be preserved and left undisturbed by the Contractor. Land survey monuments such as Section corners, 1/4 and 1/8 corners, or other alignment points of reference, including property corners of individual parcels of land, are to be respected and left undisturbed. When found in conflict with proposed work, the Contractor shall immediately notify the Authorized Representative in charge of work, whereupon instructions shall be given to the Contractor for preservation of the Survey Point. If housings or boxes for protection are required, the City shall furnish to the Contractor at no cost the necessary materials. The Contractor, in turn, will install the materials at no cost to the City.
- b. If the Contractor damages or destroys known Survey Points of reference, the Contractor shall be responsible for replacement of the monument. The work must be accomplished by a registered land surveyor in accordance with accepted procedures for such work. The Contractor shall be responsible for all incurred costs.

3.0.31 SANITARY FACILITIES - The Contractor shall furnish, install and maintain ample sanitary facilities for the workers. As the needs arise, a sufficient number of enclosed temporary toilets shall be conveniently placed as required by the sanitary codes for the state and local government. Drinking water shall be provided from an approved source, so piped or transported as to keep it safe and fresh and served from single-service containers or satisfactory types of sanitary drinking stands or fountains. All such facilities and services shall be furnished in accordance with existing and governing health regulations.



3.0.32 USE OF CITY WATER - Upon request and approval, the Contractor may obtain a water supply from the City of Muskegon fire hydrants at no cost, provided that the following conditions are met and exercised:

- a. The Contractor's superintendent shall obtain from the Water Department Superintendent a proper connection, including a meter to monitor usage.
- b. The Contractor shall only use hydrant wrenches to open and close hydrants; pipe wrenches will not be allowed.
- c. The hydrant shall be fully opened when used; volume shall be controlled by an independent hand valve.
- d. The Contractor's release shall not be granted until the hydrant connection has been returned to the Water Department and such receipt acknowledged.

3.0.33 USE OF PREMISES

- a. The Contractor shall comply with all instructions of the City of Muskegon and the ordinances and codes of the local government regarding signs, advertising, traffic, fires, explosives, danger signals and barricades.
- b. The Contractor shall confine his/her equipment, storage of materials, and construction/demolition operations to the Contract limits as shown on the drawings and as prescribed by ordinances or permits, or as may be directed by the City, and shall not unreasonably encumber the Site or public rights-of-way with his/her materials and equipment.
- c. The Contractor and his/her Subcontractors may maintain such office and storage facilities on the Site as are necessary for the proper conduct of the work. These shall be located so as to cause no interference to any work to be performed on the Site. The City shall be consulted with regard to locations.
- d. The Contractor may furnish and maintain, during the execution of this Project, adequate facilities on the Site or adjacent thereto for the use of the City's representatives.
- e. Upon completion of the Project, or as directed by the City, the Contractor shall remove all such temporary structures and facilities as have been placed on the Site, these to become his/her property, and leave the Project Site in the condition required by the Contract.

3.0.34 PARTIAL USE OF SITE IMPROVEMENTS BY THE CITY - The City of Muskegon, at its election, may give notice to the Contractor and place in use those sections of improvements which have been completed, inspected and can be accepted as complying with the Contract, if each such section is reasonably safe, fit and convenient, in the City's opinion, for the use and accommodation for which it was intended, PROVIDED THAT:

- a. The use of such sections in no way shall impede the completion of the remainder of the work by the Contractor;
- b. The Contractor shall not be responsible for any damages or maintenance costs due directly to the use of such sections;
- c. The use of such sections shall in no way relieve the Contractor of his/her liability due to having used defective materials or due to poor workmanship.

3.0.35 REMOVAL OF DEBRIS, CLEANING, ETC. - The Contractor shall periodically, or as directed during the progress of the work, remove and legally dispose of all surplus excavated material and debris, and keep the Project Site and public rights of way reasonably clear. Upon completion of the work, he/she shall remove all temporary construction facilities, debris and unused materials provided for the work, and put the whole Site of the work and public rights of way in a neat and clean condition. Trash burning on the Site will be subject to prior approval of the City of Muskegon and existing state and local regulations.

3.0.36 ACCIDENT PREVENTION

- a. The Contractor shall exercise proper precaution at all times for the protection of persons and property and shall be responsible for all damages to persons or property, either on or off the Site, which occur as a result of his/her prosecution of the work. The safety provisions of applicable laws and building, construction or demolition codes shall be observed, and the Contractor shall take, or cause to be taken, such additional safety and health measures as the City may determine to be reasonably necessary.

- b. Machinery, equipment and all hazards shall be guarded in accordance with the safety provisions of the “Manual of Accident Prevention of Construction”, published by the Associated General Contractors of America, Inc., to the extent that such provisions are not in conflict with applicable local laws.
- c. The Contractor shall maintain an accurate record of all cases of death, occupational disease and injury requiring medical attention or causing loss of time from work, arising out of and in the course of employment on work under this Contract. The Contractor shall promptly furnish the City with reports concerning these matters.
- d. The Contractor shall indemnify and save harmless the City of Muskegon from any claims for damages resulting from personal injury and/or death suffered or alleged to have been suffered by any person as a result of any work conducted under this Contract.

### 3.0.37 SPECIFICATIONS AND DRAWINGS

- a. The City of Muskegon will furnish the Contractor without charge one (1) copy of the Contract Documents, including General, Technical and Special Specifications complete with plans, drawings, maps, etc. Additional copies requested by the Contractor will be furnished at cost.
- b. In case of discrepancy, figured dimensions shall govern over scaled dimensions; Bid Proposal over plans; plans over Special Specifications; and Special Specifications over General and Technical Specifications.
- c. When discrepancies are found in drawings or Specifications, the matter shall be immediately submitted to the City, without whose decision said discrepancy shall not be adjusted by the Contractor except at his/her own risk and expense.

### 3.0.38 SHOP DRAWINGS FROM THE CONTRACTOR

- a. All required shop drawings, machinery details, layout drawings, etc., shall be submitted to the City in three (3) copies for approval sufficiently in advance of requirements to afford ample time for checking, including time for correcting, resubmitting and rechecking, if necessary.
- b. The Contractor may proceed, only at his/her own risk, with manufacture or installation of any equipment or work covered by said Shop Drawings, etc., until they are approved. No claim by the Contractor for extension of the Contract Time will be granted by reason of the Contractor’s failure in this respect.
- c. Any drawings submitted without the Contractor’s stamp of approval will not be considered and will be returned to him/her for proper resubmission. If any drawings show variations from the requirements of the Contract because of standard shop practice or other reason, the Contractor shall make specific mention of such variation in his/her letter of transmittal in order that, if acceptable, suitable action may be taken for proper adjustment of Contract Price and/or Time; otherwise, the Contractor will not be relieved of the responsibility for executing the work in accordance with the Contract even though the drawings have been approved.
- d. If a shop drawing is in accord with the Contract or indicates only a minor adjustment, in the interest of the City, without involving a change in Contract Price and/or Time, the City may approve the drawing. Such approval shall be general, shall not relieve the Contractor from his/her responsibility for adherence to the Contract or for any error in the drawing, and shall contain substantially the following language:
- e. “The modification shown on the attached drawing is approved in the interest of the City of Muskegon to effect an improvement for the Project and is ordered with the understanding that it does not involve any change in the Contract Price or Time; that it is subject generally to all Contract stipulations and covenants; and that it is without prejudice to any and all rights of the City of Muskegon under the Contract and surety bond or bonds.”

### 3.0.39 SAMPLES, CERTIFICATES AND TESTS

- a. The Contractor shall submit all equipment samples, certificates, affidavits, etc., as called for, or as required by the City, promptly after award of the Contract and acceptance of the Contractor’s bond.
- b. The Contractor shall furnish promptly all materials reasonably necessary for any tests which may be required.

- c. No such material or equipment shall be manufactured or delivered to the Site, except at the Contractor's own risk, until the required samples or certificates have been approved in writing by the City.
- d. Machinery, mechanical or other equipment, materials or articles installed or used without such prior City approval shall be at the risk of subsequent rejection.
- e. Each sample submitted by the Contractor shall carry a label giving the name of the Contractor, the Project for which it is intended, and the name of the producer. Each shall be accompanied by a certificate or letter from the Contractor which shall"
  - i. State that the sample complies with the Contract requirements;
  - ii. Give the name and brand of the product and its place of origin;
  - iii. Give the name and address of the producer;
  - iv. Include or be accompanied by all specifications or other detailed information which will assist the City in determining the acceptability of the sample promptly;
  - v. Include the statement that all materials or equipment furnished for use in the Project will comply with the samples and/or certified statements.
- f. Where machinery, mechanical or other special equipment is to be installed under this Contract, the Contractor shall furnish each manufacturer's detailed specifications to the City for approval together with full information in regard to proposed installations.
- g. Materials specified by reference to the number or symbol of a specific standard, such as an A.S.T.M. Standard, a Federal specification or other similar standard, shall comply with requirements in the latest revision thereof and any amendment or supplement thereto in effect on the date of the Invitation for Bids, except as limited to type, class or grade, or modified in such reference. The Standards referred to shall have full force and effect as though printed herein.
- h. Approval of any materials shall be general only, and shall not constitute a waiver of the City's right to demand full compliance with Contract requirements. With regard to a general approval, the City may reject materials, equipment and accessories for cause after actual delivery to the City and such check tests have been made as deemed necessary in each instance, even though such materials and articles have been given general approval.
- i. The City's Authorized Representative may test such materials as deemed advisable on the Project Site.
- j. All tests by the City will be performed in such manner as not to delay the work unnecessarily, and shall be made in accordance with the provisions of the Specifications.
- k. Any delay in the work caused by late or improper submission of samples or certificates for approval shall not be considered just cause for an extension of the Contract Time.
- l. If materials, equipment or accessories which fail to meet check tests have been incorporated in the work, the City will have the right to cause their removal and replacement by proper materials, or to demand and secure such reparation by the Contractor as is equitable.
- m. Except as otherwise specifically stated in this Contract, the costs of sampling and testing will be divided as follows:
  - i. The Contractor shall furnish without extra cost, including packing and delivery charges, all samples required for testing purposes;
  - ii. The Contractor shall assume all costs of re-testing materials which fail to meet Contract requirements;
  - iii. The Contractor shall assume all costs of testing materials offered in substitution for those found deficient; and
  - iv. The City of Muskegon will pay all other expenses for testing.
- n. Certificates of Compliance: In lieu of test samples and upon request of the City, the Contractor shall provide, upon delivery and through his/her supplier, a witnessed, notarized and signed certification complete with documented test results that the material meets or exceeds the desired specifications. The signer of the certification must be titled officer of the material company, and the documented test results must be obtained through an independent testing laboratory. Costs for such documentation shall be borne by the Contractor.

### 3.0.40 INSPECTION BY THE CITY

- a. All materials and workmanship shall be subject to inspection, examination, and/or test by the City of Muskegon at any and all time during manufacture or construction and at any and all places where such manufacture or construction is carried on. The inspection of materials as a whole, or in part, will generally be made at the Project Site, subject to the provisions of paragraph b following.
- b. Inspection of materials and appurtenances to be incorporated in the improvements embraced in this Contract may be made at the place of production, manufacture or shipment whenever the quantity justifies it. Such inspection and acceptance, unless otherwise stated, shall be final, except in regard to (1) latent defects, (2) departures from specific requirements of the Contract, (3) damage or loss in transit, or (4) fraud or such gross mistakes as amount to fraud.
- c. The City shall have the right to reject defective material and workmanship or require its correction. Unacceptable workmanship shall be satisfactorily corrected. Rejected material shall be promptly segregated and removed from the Project Site and replaced with material of specified quality without charge therefor.
- d. If the Contractor fails to proceed at once with the correction of rejected workmanship or defective material, the City may, by contract or otherwise, have the defects remedied, or rejected materials removed from the project area, and charge the cost of the same against the monies which may be due the Contractor without prejudice to any other rights or remedies of the City.
- e. The Contractor shall notify the City sufficiently in advance of back-filling or concealing any facilities to permit proper inspection. If any facilities are concealed without approval or consent of the City, the Contractor shall uncover for inspection, and recover, such facilities all at his/her own expense, when so requested by the City of Muskegon.
- f. Should it be considered necessary or deemed advisable by the City at any time before final acceptance of the entire work to make an examination of work already completed by uncovering the same, the Contractor shall, on request, promptly furnish all necessary facilities, labor and/or material.
- g. If such work is found to be defective in any important or essential respect due to the fault of the Contractor or the fault of his/her Subcontractors, the Contractor shall defray all the expenses of such examination and or satisfactory reconstruction.
  - i. If, however, such work is found to meet the requirements of the Contract, the actual cost of labor and material necessarily involved in the examination and replacement, plus 15% of such costs to cover superintendence, general expenses and profit, shall be allowed the Contractor; and he/she shall be granted in addition a suitable extension of time if completion of the work under the entire Contract has been delayed on account of the additional work involved by such request.
  - ii. A semi-final inspection will be scheduled by the City when all construction has been completed.
  - iii. When the City has accomplished its semi-final inspection, determined all deficiencies (if any) have been corrected, and the project is completed and functional, a final inspection will be scheduled.
- h. Neither inspection, testing, approval nor acceptance of the work in whole or in part by the City or its agents shall relieve the Contractor or his/her sureties of full responsibility for materials furnished or work performed not in strict accordance with the Contract.

### 3.0.41 CHANGES IN THE WORK

- a. Except for the purpose of affording protection against any emergency endangering life or property, the Contractor shall make no change in the materials used; in the specified manner of constructing and/or installing the Improvements; nor supply additional labor, services or materials beyond that actually required for the execution of the Contract, unless pursuant to a written order from the City authorizing the Contractor to proceed with the change. No claim for an adjustment of the contract price will be valid unless so ordered.
- b. The City may make changes in the scope of the work required to be performed by the Contractor under the Contract; make additions thereto; or omit work therefrom without invalidating the Contract; without relieving or releasing the Contractor from any of his/her obligations under the

- Contract or any guarantee given by him/her pursuant to the Contract; without affecting the validity of the guaranty bonds; and without relieving or releasing the surety or sureties of said bonds.
- c. All such changes in work shall be executed under the terms of the original Contract as expressly provided for.
  - d. In the case where unit prices ARE contained in the Agreement, the City may order the Contractor to proceed with desired changes in the work with the value of such changes being determined by the measured quantities involved and the applicable unit prices specified in the Contract, unless said changes increase or decrease the total contract price more than twenty-five percent (25%).

### 3.0.42 CHANGE ORDERS

- a. Change Orders shall be executed:
  - i. If applicable unit prices ARE NOT contained in the Proposal;
  - ii. If the total net change ordered by the City increases or decreases the contract price more than twenty-five percent (25%);
  - iii. If it becomes necessary to revise the completion date due to causes which are not the fault of the Contractor;
  - iv. Upon successful completion of the Project and after final quantities are in confirmation, a Change Order Balance shall be made out by the Authorized Representative and executed by both parties. This quantity balance shall identify the total project cost and allow the Contractor to present the written Request for Final Payment.
- b. **Acceptable Methods for Cost Determination:**
  - i. Unit Price Method – The City shall request and the Contractor shall submit a written proposal describing each individual unit of work and the unit price for each item.
  - ii. Lump Sum Method – The City shall request and the Contractor shall submit a written proposal describing the work and the lump-sum price for the described work.
  - iii. Cost-Plus, Limited Basis Method – If other methods are not acceptable and prompt agreement between the parties cannot be reached, the City may order the Contractor to proceed with the work on a cost-plus, limited basis. A Cost-Plus, Limited Basis is defined as the net cost of the Contractor's labor, materials and equipment plus 15% of said net cost to cover overhead and profit. The total cost not to exceed an amount to be specified.
    1. Costs not eligible to be included in the Cost-Plus, Limited Basis are: Insurances, bonds, payroll costs for the Contractor's officers or executives, managers, engineers, lawyers or administrative personnel. These typical costs are to be considered a part of the overhead factor.
  - iv. City of Muskegon Credit Method – If the City deems it not expedient to require the Contractor to correct work not done in accordance with the Contract, the City may issue a Credit Change Order to create an equitable deduction from the Contract Price. Said deduction will be made by agreement between the Contractor and the City of Muskegon and subject to settlement, in case of dispute, as provided in these Documents.
- c. Change Order Procedure – After the Contractor's proposal has been reviewed and found acceptable by both parties, the City will prepare a Change Order in accordance therewith for execution by the Contractor on the appropriate form required by the funding agency or by using the City of Muskegon change order form.
- d. **Change Order Procedure Documentation shall include:**
  - i. A detailed reason for and description of the work, its location, quantity, rate and method of payment as described above.
  - ii. A definite statement as to the resulting change in the Contract Price and/or time.
  - iii. The statement that all work involved in the change shall be performed in accordance with the Contract requirements except as modified by this Change Order.

### 3.0.43 DISPUTES AND CLAIMS

- a. All disputes arising under this Contract or its interpretation, except those disputes covered by Federal Labor Provisions, whether involving law or fact, or both, or extra work, and all claims for alleged breach of Contract shall be presented by the Contractor to the City for decision within ten (10) days of commencement of dispute.

- b. All papers pertaining to claims shall be filed in quadruplicate. Such notice need not detail the amount of the claim but shall state the facts surrounding the claim in sufficient detail to identify and prove the claim, together with its character and scope. In the meantime, the Contractor shall proceed with the work as directed.
- c. Any claim not presented within the time limit specified in Paragraph (a) above shall be deemed to have been waived, except that if the claim is of a continuing character and notice of the claim is not given within then (10) days of its commencement, the claim will be considered only for a period commencing ten (10) days prior to the receipt by the City of notice thereof.
- d. After review of the claim, the City will decide upon action to be taken. Each decision by the governing body of the City of Muskegon will be in writing and will be mailed to the Contractor by registered mail, return receipt requested, directed to his/her last known address.
- e. If the Contractor does not agree with any decision of the City, he/she shall in no case allow the dispute to delay the work but shall notify the City promptly that he/she is proceeding with the work under protest, and he/she may then except the matter in question from the final release upon Request for Final Payment in substantially.

#### 3.0.44 CLAIMS FOR EXTRA COST

- a. If the Contractor claims that any instructions by drawings or otherwise involve extra cost or extension of time, he/she shall, within ten (10) days after the receipt of such instructions, and in any event before proceeding to execute the work, submit his/her protest thereto in writing to the City stating clearly and in detail the basis of this objection. No such claim will be considered unless so made.
- b. Claims for additional compensation for extra work due to alleged errors in ground elevations, contour lines, or bench marks will not be recognized unless accompanied by certified survey data made prior to the time the original ground was disturbed, which clearly shows that errors exist which resulted, or would result, in handling more material or performing more work than would be reasonably estimated from the drawings and maps issued.
- c. Any discrepancies which may be discovered between actual conditions and those represented by the drawings and maps shall at once be reported to the City, and work shall not proceed except at the Contractor's risk until written instructions have been received by him/her from the City.
- d. If, on the basis of the available evidence, the City determines that an adjustment of the Contract Price and/or Contract Time is justifiable, the procedure shall be as provided in Item 39 (Part 3, Section I), Change Orders.

#### 3.0.45 DELAYS AND LIQUIDATED DAMAGES

- a. Liquidated Damages for Delays. If the work is not completed within the time stipulated in this Contract, including any extensions of time for excusable delays as provided, the Contractor and/or his sureties shall be liable for and shall pay to the City of Muskegon sum of one thousand two hundred fifty dollars (\$1250.00) for each calendar day of delay as fixed, agreed and liquidated damages (it being impossible to determine the actual damages occasioned by the delay), commencing from the time stipulated for completion until such work is satisfactorily completed and accepted.
- b. Excusable Delays. The right of the Contractor to proceed shall not be terminated nor shall the Contractor be charged with liquidated damages for any delays in the completion of the work DUE TO:
  - i. Any acts of government, including controls or restrictions upon or requisitioning of materials, equipment, tools or labor by reason of war, national defense or any other national emergency;
  - ii. Any acts of the City of Muskegon;
  - iii. Causes not reasonably foreseeable by the parties to this Contract at the time of the execution of the Contract which are beyond the control and without the fault or negligence of the Contractor including, but not restricted to: Acts of God or of the public enemy; acts of another contractor in the performance of some other contract with the City; fires; floods; epidemics; quarantine; restrictions; strikes; freight embargoes; and weather of unusual severity such as hurricanes, tornadoes, cyclones and other extreme weather conditions; and

- iv. Any delay of any Subcontractor occasioned by any of the causes specified in subparagraphs 1, 2 and 3 above.

PROVIDED, HOWEVER, that the Contractor promptly notify the City within ten (10) days in writing of the cause of the delay.

- c. Upon receipt of such written notification, the City shall ascertain the facts and the cause and extent of the delay. If, upon the basis of the facts and in compliance with the terms of this Contract, the delay is properly excusable, the City shall extend the time for completing the work for a period of time commensurate with the period of excusable delay through the execution of a written Change Order.

### 3.0.46 PAYMENTS TO THE CONTRACTOR

#### a. Partial Payments

- i. Partial payments will be made as specified herein for work completed and for fabricated or processed non-perishable materials delivered for the use on the project. Processing of payments will be completed as soon as practicable; however, no claim will be considered for late payment of estimates.
- ii. Partial payments will be issued on the second Friday of each month on the basis of the value of the work completed during the estimate period, less the percentage retained as specified herein, provided the written orders of the Engineer have been or are being fulfilled, provided the time for completion has not elapsed, and provided that at least one-half of the contract amount or \$1,000 has been earned during the estimate period. Said payments will be based upon estimates prepared by the Engineer of the value of the work performed, and estimates of the Engineer are subject to final balancing at the time of the final estimate. In the event that the prepared estimate is not submitted with sufficient time to process payment on the second Friday of the month, payment of the estimate will be processed for payment on the fourth Friday of the month. As a result, the Engineer's estimates may not be relied upon by a Contractor as a basis to make payment to a Subcontractor.
- iii. Before each payment by the City to the Contractor under this contract, the Contractor shall furnish the City with a certificate in duplicate, substantially to the effect that the Contractor and each Subcontractor has complied with the wage and other labor standards provisions of this contract. The Form of certificate to be used will be furnished by the City.
- iv. Before making any partial payment, the City may require the Contractor to present a verified written statement showing the amounts he/she owes for labor performed and materials furnished along with the names and addresses of the persons to whom which sums are due.
- v. In case the Contractor shall have sublet a part of the work, the statement shall also show the sum owed to the Subcontractor showing names and addresses of persons performing labor or furnishing material under that subcontract along with the respective amounts due such persons.
- vi. The City must pay the amounts due directly to the creditors of the Contractor or Subcontractor so listed, deducting the amount from that due the Contractor or Subcontractor.
- vii. Partial payments made by the City to the Contractor are monies advanced for the purpose of assisting the Contractor to expedite the work under this contract. The Contractor shall be responsible for the care and protection of all materials and work upon which payments have been made until final acceptance of such work and materials by the City.
- viii. Any such partial payments shall not constitute a waiver of the right of the City to require the fulfillment of all terms of the contract, and the delivery of all improvements embraced therein, complete and satisfactory in all details.

#### b. Withholding Payments

- i. The City may withhold from any payment otherwise due the Contractor so much as may be necessary to protect the City of Muskegon.
- ii. The City may also elect to withhold any amounts the Contractor owes to any subcontractor or materials dealer for work performed or materials furnished by them.
- iii. Any amount due to the City of Muskegon for liquidated damages, or other purposes as provided under the terms of this contract, shall be deducted from the final payment due the Contractor.
- iv. The foregoing provisions shall be construed solely for the benefit of the City of Muskegon and will not require the City Commission to determine or adjust any claims or disputes between the

- Contractor and his/her Subcontractors or materials dealers, or to withhold any monies for their protection unless the City Commission elects to do so.
- v. The failure or refusal of the City to withhold any monies from the contractor shall in nowise impair the obligations of any surety or sureties under any bond or bonds furnished under this contract.
  - vi. Right of Setoff. The City is entitled by this agreement to set off and retain from any payment to the Contractor or any Subcontractor or material supplier, all amounts which are due and owing to the City of Muskegon from said Contractor, Subcontractor, or material supplier for any reason,. The said right or setoff also applies to any unpaid taxes to be collected by the City. This right of setoff shall be subject only to the right of a surety providing bonds or guarantees for the project be due and owing to a Subcontractor or material supplier, and which are required to be paid by the surety. If no claim against any such surety has been made, then this right of setoff shall be invoked.
  - vii. This right to setoff shall not apply in the case of non-management individuals employed by a Contractor or Subcontractor who have claims solely for wages earned in the performance of labor in this project. In the event there remain outstanding such claims for labor, the right of setoff shall be subordinate to such claims even though no claim against a surety has been made.
- c. Final Payment
- i. Final payment to the Contractor shall be made subject to the furnishing of a satisfactory release of all claims against the City arising under and by virtue of this contract, other than such claims as may be specifically accepted by the Contractor from the operation of release as provided under “Disputes and Claims”.
  - ii. The Contractor shall prepare his/her Requisition for Final Payment after final inspection and acceptance by the City for all work under the contract.
  - iii. The Contractor shall additionally secure the consent of his/her surety in regard to Final Payments as well as the retainage withheld by the City.
  - iv. Requisition for Final Payment can be based upon the total project dollar amount as described in the required Balancing Change Order. The total amount of the final payment will be that amount agreed upon by the parties hereto MINUS all previous payments.
  - v. Before making final payment, the City may require the Contractor to furnish releases or receipts from all Subcontractors having performed any work and from all persons having supplied materials, equipment installed on the project, and services to the Contractor.
  - vi. If the City deems it advisable to make payment in part or full to the Contractor without requiring the furnishing of such releases or receipts, any payments so made shall in nowise impair the obligations or any surety or sureties furnished under this contract.



3.1 TIME CHANGE ORDER

**Project No.:** \_\_\_\_\_

**Contract No.:** \_\_\_\_\_

Contractor Information:

Company Name: \_\_\_\_\_

Street Address: \_\_\_\_\_

City, State Zip: \_\_\_\_\_

Contact Name: \_\_\_\_\_

Requested Time Change Order Date: \_\_\_\_\_

---

**In connection with the above referenced Contract, dated:** \_\_\_\_\_ ,  
**for the Project entitled:** \_\_\_\_\_ ,

**The following change is ordered, subject to conditions hereinafter set forth:**

**The Contract Time is extended** \_\_\_\_\_ **calendar days from the original**  
**Contract Completion Date of:** \_\_\_\_\_ **to:** \_\_\_\_\_ .

The City of Muskegon has duly determined that:

- The delay was due to unforeseeable causes beyond your control and without your fault or negligence:
- Notice of the cause of the delay was given within the time and in the manner prescribed by the Contract.
- The causes of delay justify and require an extension of the time as herein provided as a matter of legal right without the assertion of a claim by the owner for (actual) (liquidated) damages because of the Contractor’s failure to complete the work within the number of days specified by the Contract.

The aforementioned changes, and work affected thereby, are subject to all contract stipulation and covenants.  
The Rights of the city of Muskegon are not prejudiced.

All claims against the City of Muskegon which are identical to or as a consequence of the aforementioned change are satisfied

---

**Contractor Approval**

\_\_\_\_\_  
Authorized Representative Signature Date

\_\_\_\_\_  
Printed Name Title

**City of Muskegon Approval**

\_\_\_\_\_  
Authorized Representative Signature Date

\_\_\_\_\_  
Printed Name Title

\_\_\_\_\_  
Prepared By Date

3.2 CONTRACT CHANGE ORDER

CONTRACTOR		CONTRACT						DATE	11/10/2017
								<b>CHANGE ORDER</b>	
								No.	1
ITEM OF WORK	UNIT	QUANTITY	QUANTITY	QUANTITY	QUANTITY	UNIT	AMOUNT	AMOUNT	
DESCRIPTION, REASON, LOCATION OF CHANGE	OF MEASURE	PROPOSAL	AS BUILT	INCREASE +	DECREASE -	COST	INCREASE	DECREASE	
1							\$0.00	\$0.00	
2							\$0.00	\$0.00	
3							\$0.00	\$0.00	
							<b>TOTALS</b>	\$0.00	\$0.00
							ORIGINAL CONTRACT PRICE:	\$0.00	
							NET +/-	\$0.00	
							REVISED CONTRACT PRICE:	\$0.00	
<b>ENGINEERING DEPARTMENT</b>		<b>CONTRACTOR APPROVAL</b>				<b>CITY OF MUSKEGON APPROVAL</b>			
		AUTHORIZED REPRESENTATIVE AND DATE				AUTHORIZED REPRESENTATIVE AND DATE			
PREPARED BY		DATE		PRINTED NAME AND TITLE				PRINTED NAME AND TITLE	



3.3 CONTRACTOR'S CERTIFICATE & RELEASE REQUEST FOR FINAL PAYMENT

FROM: \_\_\_\_\_  
(Name of Contractor)

TO: The City of Muskegon

**RE: Contract No.**

ENTERED INTO THE \_\_\_\_\_ DAY OF \_\_\_\_\_ BETWEEN THE CITY OF MUSKEGON,  
933 TERRANCE ST, MUSKEGON, MICHIGAN 49443

AND

\_\_\_\_\_  
(Contractor Street Address) (City) (State) (ZIP)

**FOR THE:** \_\_\_\_\_  
(Name of Operations to be performed)

**UNDER THE CONTRACT ENTITLED:** \_\_\_\_\_

**PROJECT NO.** \_\_\_\_\_  
**LOCATED IN THE CITY OF MUSKEGON, MICHIGAN;**

**KNOW ALL MEN BY THESE PRESENTS:**

1. The undersigned hereby certifies that there is due from and payable by the CITY OF MUSKEGON to the CONTRACTOR under the Contract and duly approved Change Orders and modifications THE BALANCE OF \$ \_\_\_\_\_.
2. The undersigned further certifies that in addition to the amount set forth in Paragraph 1, there are outstanding and unsettled the following items which the Contractor claims are just and due and owing by the City of Muskegon to the Contractor:
  - a. \_\_\_\_\_
  - b. \_\_\_\_\_
  - c. \_\_\_\_\_
  - d. \_\_\_\_\_

(Itemize claims and amounts due; if none, so state)
3. The undersigned further certifies that all work required under this Contract, including work required under Change Orders Nos. \_\_\_\_\_, has been performed in accordance with the terms thereof, and that there are no unpaid claims for materials, supplies or equipment and no claims of laborers or mechanics for unpaid wages arising out of the performance of this Contract, and that the wage rates paid by the Contractor and all Subcontractors were in conformity with the Contract provisions relating to said wage rates.

4. Except for the amounts stated under Paragraphs 1 and 2 hereof, the undersigned has received from the CITY OF MUSKEGON all sums of money payable to the undersigned under or pursuant to the above-mentioned Contract or any modification or change thereof.
5. That in consideration of the payment of the amount stated in Paragraph 1 hereof, the undersigned does hereby release the CITY OF MUSKEGON from any and all claims arising under or by virtue of this Contract, except the amount listed in Paragraph 2 hereof; provided, however, that if for any reason the City of Muskegon does not pay in full the amount stated in Paragraph 1 hereof, said deduction shall not affect the validity of this release, but the amount so deducted shall be automatically included under Paragraph 2 as an amount which the Contractor has not released but will release upon payment thereof.

The Contractor further certifies that upon the payment of the amount listen in Paragraph 2 hereof, and of any amount which may be deducted from Paragraph 1 hereof, the Contractor will release the City of Muskegon from any and all claims of any nature whatsoever arising out of said Contract or modification thereof, and will execute such further releases or assurances as the City may request.

IN WITNESS WHEREOF, the undersigned has signed and sealed this instrument this \_\_\_\_\_ day of \_\_\_\_\_, 20 \_\_\_\_\_.

(SEAL)

CONTRACTOR: \_\_\_\_\_

BY: \_\_\_\_\_

\_\_\_\_\_  
(Printed name and title of signer)

\_\_\_\_\_, the affiant signing this instrument, being first duly sworn on oath, deposes and says: First, that he/she is the

\_\_\_\_\_ of the \_\_\_\_\_  
(Title) (Name of company)

Second, that he/she has read the foregoing certificate by him/her subscribed as

\_\_\_\_\_ of the \_\_\_\_\_  
(Title) (Name of company)

Affiant further states that the matters and things stated are, to the best of his/her knowledge and belief, true.

Affiant: \_\_\_\_\_

Subscribed and sworn to before me this \_\_\_\_\_ day of \_\_\_\_\_, 20\_\_\_\_\_

\_\_\_\_\_  
(Notary)

My commission expires \_\_\_\_\_

3.4 CONTRACTOR AFFIDAVIT - SURETY RELEASE

State of \_\_\_\_\_ )  
County of \_\_\_\_\_ ) ss.

\_\_\_\_\_  
(Contractor)

Being duly sworn, deposes and says that he/she entered into a contract with the City of Muskegon on the \_\_\_\_\_ day of \_\_\_\_\_ for the construction of the City of Muskegon.

Project No. \_\_\_\_\_

Project Title: \_\_\_\_\_

Deponent further says that the work under the terms of the said contract has been completed and all indebtedness incurred by him/her to subcontractors, material suppliers, and persons in his/her employ has been paid in full.

Deponent further says this affidavit is furnished before final payment, or before the ten percent (10%) withheld in accordance with the contract may be reduced.

Deponent further says this affidavit is made pursuant to provisions of Public Act 179 of 1891, section 4, as amended.

Witnesses: \_\_\_\_\_ SIGNED \_\_\_\_\_  
\_\_\_\_\_ \_\_\_\_\_  
\_\_\_\_\_ \_\_\_\_\_

Subscribed and sworn to before me  
This \_\_\_\_\_ day of \_\_\_\_\_, 20\_\_\_\_  
\_\_\_\_\_  
\_\_\_\_\_  
Title

3.5 CONSENT OF SURETY

We, as surety on the above described contract, hereby give our consent to the payment to the Contractor as indicated above.

Date\*: \_\_\_\_\_

Signed: \_\_\_\_\_

(Attorney-in-fact)

**NOTE: Two completed copies of this or similar form MUST BE SUBMITTED to and accepted by the City of Muskegon BEFORE REDUCTION OF 10% RETAINAGE AND FINAL PAYMENT WILL BE MADE.**

**\*Date contract awarded by the city commission**

## **SECTION 2**

### 3.6 AFFIRMATIVE ACTION

**NOTICE OF REQUIREMENT FOR AFFIRMATIVE ACTION  
TO INSURE EQUAL EMPLOYMENT OPPORTUNITY AND  
PROHIBITING DISCRIMINATION IN EMPLOYMENT  
(Federal Executive Order 11243)  
Michigan: Elliot-Larson Civil Rights Act**

The attention of bidders is particularly called to the requirements for ensuring that employees and applicants for employment are not discriminated against.

During the performance of this contract, the contractor agrees as follows:

The contractor will not discriminate against any employee or applicant for employment because of religion, race, color, national origin, age, sex, height, weight, familial status, marital status, disability, sexual orientation or gender identity, or status as a Vietnam Era Veteran. The contractor will take affirmative action to ensure that applicants are employed and that employees are treated fairly during employment, without regard to their religion, race, color, national origin, age, sex, height, weight, familial status, marital status, disability, sexual orientation or gender identity, or veteran background. Such action shall include, but not be limited to, the following: employment, promotion, demotion, or transfer; recruitment or recruitment advertising, layoff or termination; rates of pay or other forms of compensation; selection for training, including apprenticeship.

#### LOCAL EMPLOYMENT EFFORT

The City of Muskegon requires that the contractor must hire local trades and labor employees from the City of Muskegon, County of Muskegon and/or this SMSA (Standard Metropolitan Statistical Area) for the duration of this project, insofar as these are available to perform the necessary work. Supervisory and/or technical staff officials are exempt from this requirement.

#### LABOR STANDARDS PROVISION EMPLOYMENT AND PREVAILING WAGE AND SALARY REQUIREMENTS

The attention of bidders is particularly called to the requirements covered in these documents concerning the payment of not less than the prevailing wage and salary rates specified, and in regard to conditions of employment with respect to certain categories and classifications of employees.

All laborers and mechanics employed by this contract shall be paid unconditionally and not less than once each week, and without subsequent deduction or the rebate on any account (except such payroll deductions as are permitted by the applicable regulations issued by the City of Muskegon).



### **SECTION 3**

### 3.7 ADOPTED LABOR STANDARDS PROVISIONS

The following clause is applicable unless this contract is exempt under the rules and regulations of the Secretary of Labor issued pursuant to Executive Order No. 11246 of September 24, 1965 (30FR 12319), as amended. During the performance of this contract, the contractor agrees as follows:

- (1) The contractor will not discriminate against any employee or applicant for employment because of race, color, religion, sex or natural origin. The contractor will take affirmative action to ensure that applicants are employed, and that employees are treated during employment, without regard to their race, color, religion, sex, or national origin. Such action shall include, but not be limited to the following: employment, upgrading, demotion, or transfer; recruitment or recruitment advertising; layoff or termination; rates of pay or other forms of compensation; and selection for training, including apprenticeship. The contractor agrees to post in conspicuous place, available to employees and applicants for employment, notices to be provided by the contracting officer setting for the provisions of this nondiscrimination clause.
- (2) The contractor will, in all solicitations or advertisements for employees placed by or on behalf of the contractor, state that qualified applicants will receive consideration for employment without regard to race, color, religion, sex, or national origin.
- (3) The contractor will send to each labor union or representative of workers with which he has a collective bargaining agreement or other contract or understanding, a notice to be provided by the agency contracting officer, advising the labor union or workers' representative of the contractor's commitments under Section 202 of Executive Order No. 1246 of September 24, 1965, and shall post copies of the notice in conspicuous places available to employees and applicants for employment.
- (4) The contractor will comply with all provisions of Executive Order No. 11246 of September 24, 1965, and of the rules, regulations, and relevant orders of the Secretary of Labor.
- (5) The contractor will furnish all information and reports required by Executive Order No. 11246 of September 24, 1965, and by the rules, regulations and orders of the Secretary of Labor, or pursuant thereto, and will permit access to his books, records, and accounts by the contracting agency and the Secretary of Labor for the purposes of investigation to ascertain compliance with such rules, regulations, and orders.
- (6) In the event of the contractor's noncompliance with the nondiscrimination clauses of this contract or with any of such rules, regulations or orders, this contract may be canceled, terminated, or suspended in whole or in part and the contractor may be declared ineligible for further Government contracts in accordance with the procedures authorized in Executive Order No. 11246 of September 24, 1965, and such other sanctions may be imposed and remedies invoked as provided in Executive Order No. 11246 of September 24, 1965, or by rule, regulation, or order of the Secretary of Labor, or as otherwise provided by law.
- (7) The contractor will include the provision of paragraphs (1) through (7) in every subcontract or purchase order unless exempted by rules, regulations, or orders of the Secretary of Labor issued pursuant to Section 204 of Executive Order No. 11246 of September 24, 1965, so that such provisions will be binding upon each subcontractor or vendor. The contractor will take such action with respect to and subcontract or purchase order as may be directed by the Secretary of Labor as a means of enforcing such provisions including sanctions for noncompliance: Provide, however, that in the event the contractor becomes involved in, or is threatened with, litigation with a subcontractor or vendor as a result of such direction. The contractor may request the United States to enter into such litigation to protect the interests of the United States.

### 3.8 EQUAL EMPLOYMENT OPPORTUNITY CLAUSE

(Incorporated by Reference)

The Equal Employment Opportunity Clause required under Executive Order 11246, the affirmative action commitment for disabled veterans and veterans of the Vietnam era, set forth in 41 CFR 60-250.4 the affirmative action clause for handicapped workers, set forth in 40 CFR 60-741.4 and the related regulations of the Secretary of Labor. 40 CFR Chapter 60, are incorporated by reference in this purchase order. By accepting this purchase order, vendor certifies that it complies with the authorities cited above, and that it does not maintain segregated facilities or permit its employees to perform services at locations where segregated facilities are maintained, as required by 41 CFR 60-1.8

### 3.9 ANTI-KICKBACK ACT

**NOTICE TO CONTRACTORS:** The Contractor shall comply with the applicable regulations of the Secretary of Labor, United States Department of Labor, made pursuant to the Copeland Anti-Kickback Act (Title 40 U.S.C., Section 276c), and any amendment or modifications thereof, shall cause appropriate provisions to be inserted in subcontracts to insure compliance therewith by all subcontractors subject thereto, and shall be responsible for the submission of affidavits required by subcontractor thereunder, except as said Secretary of Labor may specifically provide for reasonable limitations, variations, tolerance, and exemptions from the requirements thereof.

#### Copeland “Anti-Kickback” Act Policy

The Copeland “Anti-Kickback” Act prohibits contractors or subcontractors engaged in building construction or repair from persuading an employee to give up any part of the compensation to which he or she is entitled under his or her employment contract.

**NOTICE TO MUNICIPAL EMPLOYEES:** *Any employee who offers or approves the offer of a business consideration must ensure that it is ethical and proper in all respects. The offer of a business consideration cannot reasonably be interpreted as an attempt to gain an unfair business advantage or otherwise reflect negatively on the reputation of the City of Muskegon and/or the recipient. The business consideration shall not violate this anti-kickback policy.*

The City of Muskegon’s (Muskegon) staff, representatives, and contractors are prohibited from receiving unreasonable compensation from grantors, grantees, contractors, applicants, or any other person or individual for the purpose of receiving preferential treatment of any kind. The guidelines below define Muskegon’s policy toward kickbacks and the penalties for offering kickbacks to Muskegon employees, representatives or contractors.

**Definition: “Kickback”** for the purposes of this policy (excluding de minimis gifts), means substantial money, fees, commission, gifts, gratuity, object of value, or offer of employment, which is provided or offered, directly or indirectly, to any City of Muskegon employee, contractor or contracted employee, vendor or vendor employee, or consultant for the purpose of improperly obtaining or rewarding favorable treatment in connection with a City of Muskegon project or contract.

#### **This policy prohibits any person or organization from:**

Providing or attempting to provide or offering to provide kickbacks;  
Soliciting, accepting or attempting to accept kickbacks; or  
Including, directly or indirectly, the amount of kickbacks in any contract awarded by City of Muskegon, contractors, or subcontractors.

*Any employee found to be in violation of this policy will be subject to an investigation by the City of Muskegon’s Compliance Officer to determine if the policy was infringed upon.*

*Depending on the results of the investigation, appropriate discipline will be determined. The employee may be subject to civil or criminal penalties as provided under U.S. law.*

Any applicant, grantee, contractor, consultant, or vendor in violation of this policy will be prohibited from participation in any City of Muskegon project, contract, or activity and may be subject to additional civil or criminal penalties as provided under U.S. law (Title 40 U.S.C., Section 276c).

Muskegon reserves the right to recover damages from any person who knowingly engages in such prohibited conduct and from any person whose employee, contractor, or subcontracted employee provides, accepts, or charges a kickback.

## **SECTION 4**

3.10 PREVAILING WAGE DECISION

**THIS IS NOT A PREVAILING WAGE PROJECT**

**SECTION 00 91 17**  
**ADDITIONS TO GENERAL CONDITIONS**

**PART 1 – GENERAL**

**GENERAL PURPOSE OF THESE ADDITIONS TO GENERAL CONDITIONS**

- A. These Additions to the General Conditions were prepared by Dixon Engineering, Inc. using paragraphs from Engineering Joint Contract Documents Committee (EJCDC) General Conditions GC-700 -18 which were modified by DIXON as they relate to the coating industry. The General Conditions of this Contract were prepared by the Owner. These Additional General Conditions are intended to supplement the Owner's General Conditions as they relate to this specific project. Two examples are:
1. The Owner's General Conditions detail the payment process, how to submit a Request for Payment application, what form to use and when and where to submit the application. These Additions detail how DIXON calculates approval of a pay request, no payment for stored materials, percentage complete calculation methodology, etc.
  2. In the General Conditions Liquidated Damages are defined, when, where and amount. In these Additions the method of calculating claimed wind and weather days is detailed.
- B. This Addition to General Conditions follow the EJCDC format and the Article numbers reflect the Article number in the 2018 edition of the EJCDC General Conditions. Note that not all Articles or subsections are referenced.

**DISCREPANCIES BETWEEN OWNER'S GENERAL CONDITIONS AND THESE ADDITIONS.**

- A. If the conflict is administrative in nature, then the Owner's General or Supplemental Conditions govern. Examples are Pay Request procedures, filing a Claim, etc.
- B. If the conflict is of a technical nature, then these Additions govern.
- C. An issue determined to be in conflict in a specific item does not void other non-conflicting paragraphs in the same Article number.
- D. Bidders are required to familiarize themselves with all the General and Supplemental Conditions of the contract, as well as these Additions.
- E. In all cases of discrepancies between the General Conditions, the Supplemental Conditions, these Additions, the Technical Specifications and/or the Drawings, the Engineer shall be notified. The specifications shall govern over the drawings.
- F. If Work proceeds without Contractor obtaining proper interpretations of the conflicting issues from the Engineer, any installed Work that is not in accordance with the specification, and best practices shall be replaced at no additional cost and

other costs that may occur are also the responsibility of the Contractor if they were aware of the conflict.

## **ARTICLE 1      DEFINITIONS AND TERMINOLOGY**

### **1.01    DEFINED TERMS**

- A. Construction Industry Definitions: These definitions are taken from the EJCDC General Conditions C-700-18, the 2018 edition and some were modified by DIXON to be specific to the coating industry.
1. *Bulletin*—If time permits, a Bulletin is issued prior to a Change Order. A Bulletin is an inquiry of the Contractor of the cost to complete the work described in the Bulletin. It is intended as the basis of a Change Order if all parties reach agreement. A Bulletin may be considered as the same as a Change Proposal except that a Bulletin is generated by the Engineer because it generally requires specifications to be addressed.
  2. *Change Order* is a written order to the contractor signed by the owner, issued after execution of the contract, authorizing a change in the work or an adjustment in the contract sum or the contract time. A document which is signed by Contractor and Owner and authorizes an addition, deletion, or revision in the Work or an adjustment in the Contract Price or the Contract Times, or other revision to the Contract, issued on or after the Effective Date of the Contract.
  3. *Change Proposal*—A written request by Contractor, duly submitted in compliance with the procedural requirements set forth herein, seeking an adjustment in Contract Price or Contract Times, or both; contesting an initial decision by Engineer concerning the requirements of the Contract Documents or the acceptability of Work under the Contract Documents; challenging a set-off against payments due; or seeking other relief with respect to the terms of the Contract.
  4. *Constituent of Concern (CC)*—Asbestos, petroleum, radioactive materials, polychlorinated biphenyls (PCBs), lead based paint (as defined by the HUD/EPA standard) hazardous waste, and any substance, product, waste, or other material. Lead, chrome, and other by-products of paint removal, as well as strippers, new coatings, and thinners, are to be included in this definition. Coating industry related CC, from new or from previous projects cannot be the basis of Contract Termination or Change Proposal by the Contractor.
  5. *Drawings*—The part of the Contract that graphically shows the scope, extent, and character of the Work to be performed by Contractor. A Shop Drawing is not a Drawing and is not part of the Contract Documents.
  6. *Electronic Document*—Any Project-related correspondence, attachments to correspondence, data, documents, drawings, information, or graphics, including but not limited to Shop Drawings and other Submittals, that are in an electronic or digital format.
  7. *Electronic Means*—Electronic mail (email), upload/download from a secure Project website, or other communications methods that allow: (a) the transmission or communication of Electronic Documents; (b) the documentation of transmissions, including sending and receipt; (c) printing of the transmitted



Electronic Document by the recipient; (d) the storage and archiving of the Electronic Document by sender and recipient; and (e) the use by recipient of the Electronic Document for purposes permitted by this Contract. Electronic Means does not include the use of text messaging, or of Facebook, Twitter, Instagram, or similar social media services for transmission of Electronic Documents.

8. *Field Order*—A written order issued by Engineer which requires minor changes in the Work but does not change the Contract Price or the Contract Times.
9. *Hold Point*—A point in the construction sequence when the Contractor is required to stop work on that portion of the project until Work has been Site reviewed by RPR or Project Manager.
10. *Non-Conformance Report*—A report written by the Engineer or Resident Project Representative, to document the Contractor’s Work that does not meet requirements of the specifications or contract.
11. *Performance Specifications* –Specifications that require the manufacturer or supplier of equipment, materials, or systems to design, manufacture, deliver, and install products to achieve specific results under stipulated conditions of operation and in environments described in applicable Specification Sections.
12. *Ready for Final Payment* – This term is used to define a time when Liquidated Damages begin, separate from Liquidated damages for failure to meet Substantial Completion Date. Ready for Final Payment Date is generally listed 30 days after Substantial Date. All punch list items are to be completed, Site cleaned and restored, and equipment removed. At the option of the Owner this LD may be in addition (cumulative) with an LD for failure to meet Substantial Completion Date.
13. *Resident Project Representative*—The authorized representative of Engineer assigned to assist Engineer at the Site. As used herein, the term Resident Project Representative or “RPR” includes any assistants or field staff of Resident Project Representative.
14. *Schedule of Values*—A schedule, prepared and maintained by Contractor, allocating portions of the Contract Price to various portions of the Work and used as the basis for reviewing Contractor’s Applications for Payment. The Schedule of Value Form is supplied in these Bidding Documents as Section 00 06 00. This Schedule is to be submitted with the Bid. Adjustment of Schedule of Values by Engineer will not change the total Bid as calculated by the Contractor completing the Schedule of Values.
15. *Set-Off*—Owner may withhold from payment including Final Payment an amount equal to additional expenses incurred by Owner which were the responsibility of the Contractor. Such expenses may include additional engineering expenses related to excess review of incomplete submittals of shop drawings, pay requests, or bonds and insurance, excess Requests for Information, excess tests and inspections and return visit to site to complete a reinspection of a previously failed inspection, increase inflation in Engineering fees that result from Contractor delaying project into the next season; additional expenses incurred by Owner resulting from Contractor failure to clean site, rehabilitate Site and other construction related expenses resulting from Contractor not completing their contractual obligations.

16. *Site*—Lands or areas indicated in the Contract Documents as being furnished by Owner upon which the Work is to be performed, including rights-of-way and easements, and such other lands furnished by Owner which are designated for the use of Contractor.
17. *Specifications*—The part of the Contract that consists of written requirements for materials, equipment, systems, standards, and workmanship as applied to the Work, and certain administrative requirements and procedural matters applicable to the Work.
18. *Submittal*—A written or graphic document, prepared by or for Contractor, which the Contract Documents require Contractor to submit to Engineer, or that is indicated as a Submittal in the Schedule of Submittals accepted by Engineer. Submittals may include Shop Drawings and Samples; schedules; product data; Owner-delegated designs; sustainable design information; information on special procedures; testing plans; results of tests and evaluations, source quality-control testing and inspections, and field or Site quality-control testing and inspections; warranties and certifications; Suppliers' instructions and reports; records of delivery of spare parts and tools; operations and maintenance data; Project photographic documentation; record documents; and other such documents required by the Contract Documents. Submittals, whether or not approved or accepted by Engineer, are not Contract Documents. Change Proposals, Change Orders, Claims, notices, Applications for Payment, and requests for interpretation or clarification are not Submittals
19. *Substantial Completion*—The time at which the Work (or a specified part thereof) has progressed to the point where, in the opinion of Engineer, the Work (or a specified part thereof) is sufficiently complete, in accordance with the Contract Documents, so that the Work (or a specified part thereof) can be utilized for the purposes for which it is intended. The terms “substantially complete” and “substantially completed” as applied to all or part of the Work refer to Substantial Completion thereof. On tank projects, date of substantial completion is the date the tank is, or would have been returned to service, except for voluntary delay by Owner. Date of Substantial Completion is after complete cure, disinfection, and testing.
20. *Work Change Directive*—A written directive to Contractor issued on or after the Effective Date of the Contract, signed by Owner and recommended by Engineer, ordering an addition, deletion, or revision in the Work.

B. *Defective*:

1. The word “defective,” when modifying the word “Work,” refers to Work that is unsatisfactory, faulty, or deficient in that it:
  - a. does not conform to the Contract Documents; or
  - b. does not meet the requirements of any applicable inspection, reference standard, test, or approval referred to in the Contract Documents; or
  - c. has been damaged prior to Engineer’s recommendation of final payment (unless responsibility for the protection thereof has been assumed by Owner at Substantial Completion in accordance with Paragraph 15.03 or 15.04).
  - d. All work completed that is rejected by an unresolved non-conformance report.

## **ARTICLE 2      PRELIMINARY MATTERS**

### **2.04    PRECONSTRUCTION CONFERENCE**

#### **A. Preconstruction Conference is herein called Preconstruction Meeting:**

1. The Engineer will schedule a Preconstruction Meeting to be attended by Owner, Engineer, and Contractor. Prior to beginning any Work, Contractor shall submit to the Engineer, a Project Schedule and all other required Submittals for the project. If the schedule is aggressive, working overtime, weekends, and/or holidays, that time shall be reflected in the Project Schedule. Once the project has begun, the Contractor shall carry the Project Schedule to completion without delay.
2. Attend a Preconstruction Meeting that may be scheduled by the Owner at a mutually agreeable time after contract preconditions, bonds, certificates of insurance, and other requirements have been met.
3. A corporate officer, or someone with legal authority to obligate the company/corporation, project manager (if different from officer), and the intended superintendent shall attend. If project superintendent does not attend the meeting, it shall be the Contractor's responsibility to supply the information discussed at the meeting to the field superintendent.
4. The Owner will be represented by the project contact person, and the Engineer by the Project Manager, or a Contract Administrator.
5. All containment, personal hygiene, and lead control issues required in this contract will be reviewed. Be prepared to commit designated "Competent Person(s)" to responsibilities of confined space, scaffold rigging, lead, etc.

#### **B. Progress Meetings:**

1. The Project Manager or Owner will schedule Progress Meetings to be held on the job Site whenever needed to supply information necessary to prevent job interruptions, to observe the Work, or to inspect completed Work. The Contractor shall be represented at each progress meeting by persons with full authority to act for the Contractor in regard to all portions of the Work.

## **ARTICLE 3      CONTRACT DOCUMENTS: INTENT REQUIREMENTS, REUSE**

### **3.01    INTENT**

- A. The drawings and specifications are intended to include all Work and materials necessary for completion of the Work. Any incidental item of material, labor, or detail required for the proper execution and completion of the Work and omitted from either the drawings or specifications or both, but obviously required by governing codes, local regulations, trade practices, operational functions, and good

workmanship, shall be provided as a part of the contract Work without extra cost, even though not specifically detailed or mentioned.

## **ARTICLE 4 COMMENCEMENT AND PROGRESS OF THE WORK**

### **4.01 COMMENCEMENT OF CONTRACT TIMES**

- A. Contractor shall start to perform the Work on the date when the Contract Times commence to run. No Work shall be done at the Site prior to such date except as recommended immediately following or by written authorization of the Owner AND the Engineer (Engineer must be able to schedule appropriate RPR for Project.) Contract time is governed by out-of-service time. The Contractor is encouraged to deliver equipment to the Site prior to Contract Start. The Site will be available up to two (2) weeks prior to agreed drainage date. Contractor is also encouraged to rig the structure, complete containment installation, and complete weld repairs that do not affect the wet interior prior to draining of the tank. The amount of Work completed shall have been approved at the Preconstruction Meeting. Since the tank is not out of service these dates do not apply against Out of Service time but may require scheduling RPR services (see Section 00 91 19.01 Scheduling for RPR Services.)
- B. Delaying Work start for the convenience of the Contractor may require Owner to Set off inflation increased Engineering or RPR expenses against Contractor's Request for Payment.

### **4.05 DELAYS IN CONTRACTOR'S PROGRESS**

- A. Liquidated Damages
  - 1. Contract time is governed by out-of-service time.
  - 2. On tank projects, date of substantial completion is the date the tank is or would have been returned to service, except for voluntary delay by Owner. Date of substantial completion is after complete cure, disinfection, and testing. A voluntary delay in filling by Owner, or delay that is no fault of the Contractor may extend Substantial Completion date.
  - 3. Abnormal weather conditions are defined as weather conditions that are at variance with the routine. An example of the determination procedure and of the required claim format is:
    - Project length: 45 days
    - Substantial completion date: June 30<sup>th</sup>.
    - Start date: May 16<sup>th</sup>.
    - 3 years of data\* 2019, 2020, 2021
    - Average number of rain/wind days: 9
    - Actual number of rain/wind days\*\*: 12
    - Claim for time extension: 3 days

4. \*Submit weather history from nearest weather reporting station for three (3) previous years from the same time period. Submit formal, by simple claim (use format above).
5. \*\*Rain/wind day is a rain or wind day where either rain and/or wind conditions exceeded safe Work conditions or were outside the parameters of good paint practices. Wind days are winds in excess of 20 mph for over four (4) hours during normal Work hours, and rain days having measurable precipitation.
6. Weather Claim Evaluation: Engineer will evaluate claim and make sole determination as to whether days meet criteria. Engineer will disallow dates where Work could have been completed on the interior; dates that result from the Contractor's Work practices (i.e. complete wet interior first and then move to exterior). Good weather days not used will count against claim.
7. Claimed rain/wind days that occur after the scheduled Substantial Completion Date or an extended Substantial Completion Date will not be awarded. Days past Substantial Completion and good weather days that were not used for Productive Work will be considered "days within the control of the Contractor."

## **ARTICLE 5 SITE; SUBSURFACE AND PHYSICAL CONDITIONS; HAZARDOUS ENVIRONMENT CONDITIONS**

### **5.02 USE OF SITE AND OTHER AREAS**

#### **A. Site:**

1. Protection - The Contractor is responsible for the protection of property during the period of construction and shall exercise care to prevent damage to structures, utility services, storm and sanitary drainage systems, lawns, trees, plant material, fences, walks, drives, roadways, and other improvements in and adjacent to the area of Work under the contract. Any damage to property resulting from the Contractor's operations shall be repaired or replaced by the Contractor at their expense.
2. The Contractor shall be responsible for all injury to Work in process of construction, and for all property or materials stored at the premises that may be damaged or stolen while the Work is in his care, at Contractor's expense.
3. The Contractor shall confine the apparatus, the storage of materials, and the operations of his Workers to limits indicated by law, ordinance, permits, or direction of the Engineer, and shall not unreasonably encumber the premises with his materials.
4. Maintenance
  - a. Provide labor and material necessary to maintain the Site in a safe condition.
  - b. Keep the premises free from accumulation of waste materials, rubbish, and other debris resulting from the Work.

- c. At completion of the Work, remove all waste materials, rubbish, and debris from about the premises, as well as all tools, construction equipment, machinery, and surplus materials.
  - d. At the Contractor's expense, repair damage that may have occurred to any permanent structure completed under the contract Work, or to private or public property.
  - e. Notify the Owner of your intentions and the reasons why, if it is necessary to protect adjacent houses, cars, etc. During clean-up these areas will be considered as part of the Site and shall be cleaned accordingly.
  - f. Failure to continually maintain the Site or to immediately clean the Site after a complaint or project completion may result in the Owner completing the Work by hire or by the Owner's forces. All cost would be responsibility of the Contractor, subject to Set off.
  - g. Restore Site to preconstruction condition:
    - i. Refill holes and level area around the construction Site for the Site to the original grade.
    - ii. Bring soil to a friable condition by disking, harrowing, or otherwise loosening and mixing to a depth of 3 in. – 4 in. Thoroughly break all lumps and clods.
    - iii. Rake area to be seeded. Sow seed at a minimum rate of 220 lbs./acre.
5. Cleaning - Prior to Substantial Completion of the Work Contractor shall clean the Site and the Work and make it ready for utilization by Owner. At the completion of the Work, but prior to Ready for Final Payment, Contractor shall remove from the Site and adjacent areas all tools, appliances, construction equipment and machinery, and surplus materials and shall restore to original condition all property not designated for alteration by the Contract Documents.

### **5.03 SUBSURFACE AND PHYSICAL CONDITIONS**

- A. Locations of all buried utility service lines in or adjacent to the Work area that are not shown on the drawings will be located by the Contractor through the local utility locating agency and marked with warning stakes. The Contractor shall be responsible for the protection of all utility service lines that are to remain. Damage to any such utility service lines, pipes, etc. resulting from the Contractor's operations shall be repaired or replaced by the Contractor at their expense. Underground Work in the coating industry involves drilling for anchors for containment systems. The painting of pit piping will be considered subsurface Work. For this type of Work the Contractor must rely on Utility Locating Services and not Technical Data from Owner, or in the case of pits, a visual inspection. Contractor shall notify each utility before digging for anchors or for any reason. Before starting, call in advance or/as required by the individual agencies: Call 811 or appropriate agency in the state of the project.

**5.06 HAZARDOUS ENVIRONMENTAL CONDITIONS AT SITE**

- A. Contractor shall not be responsible for removing or remediating any Hazardous Environmental Condition (Constituents of Concern) encountered, uncovered, or revealed at the Site unless such removal or remediation is expressly identified in the Contract Documents to be within the Scope of the Work or eventually identified as being caused or created by the Contractor.
- B. Power Lines – Antennas – Electrical Wiring
  - 1. If overhead power lines present an unsafe Work condition as determined by OSHA, Owner or utility, the Contractor at their expense and coordination, shall have the utility temporarily relocate, move, or cover lines, eliminating the hazard.
  - 2. Unless stated differently in Contract Documents, protect all antennas, controls, cables, and associated property of Owner’s equipment or material on, in or near the structure during Work. Design construction procedures to maintain operation of antenna system. If antennas are removed from the structure protect all telecommunication equipment remaining in place.
  - 3. Unless stated differently in the Contract Documents, protect all electrical lines and controls including 110/220 V. service lines, cathodic wiring, lights, globes, outlets, and service boxes. Protect associated property of private telecommunication companies (911, school buses, etc.) from damage during Work. Design construction procedures to maintain operation of telecommunication systems.

**ARTICLE 6 BONDS AND INSURANCE**

**6.01 PERFORMANCE, PAYMENT, AND MAINTENANCE BONDS (NOT BID BONDS)**

- A. Supply a Maintenance (Warranty) Bond for two (2) years at 50% of the contract price, to ensure any repair work required or detected as a result of the (13) months (1 year) Post Construction inspection. The repair scheduling may be delayed several months for Contractor’s schedule or Owner’s operational requirements. This bond is to remain in effect until repairs have been completed and accepted. Per Technical Specifications, if repairs exceed 10% of any area, then the warranty and bond shall be extended another year. The maintenance (warranty) bond must be issued by the same surety that issues the performance bond.

## **ARTICLE 7      CONTRACTOR'S RESPONSIBILITIES**

### **7.01      CONTRACTOR'S MEANS AND METHODS OF CONSTRUCTION**

- A. Contractor shall supervise, direct, control, and have authority over or be responsible for Contractor's means, methods, techniques, sequences, or procedures of construction, and the safety precautions and programs incident thereto.
- B. Any plan or methods of accomplishing the work suggested to the contractor by the Engineer or other representative of the Owner, but not specified or required, shall be used at the contractor's own risk and responsibility. The Engineer and Owner assume no responsibility.
- C. Contractor shall comply with Laws and Regulations applicable to the performance of the Work.
- D. Contractor's shall perform the Work in accordance with the Contract Documents. Contractor's obligation to perform under terms of Contract and complete the Work in accordance with the Contract Documents is absolute.
- E. Contractor shall be responsible for the acts or omissions of Contractor and of any Subcontractor, any Supplier, and of any other individual or entity performing any of the Work.

### **7.02      SUPERVISION AND SUPERINTENDENCE**

- A. Contractor shall supervise, inspect, and direct the Work competently and efficiently, devoting such attention thereto and applying such skills and expertise as may be necessary to perform the Work in accordance with the Contract Documents.
  - 1. At all times during the progress of the Work, Contractor shall assign a competent resident superintendent who shall not be replaced without written notice to Owner and Engineer except under extraordinary circumstances.
  - 2. Resident superintendent shall be fluent in English to the level of competency to complete responsibilities of the Contractor and to communicate with the RPR. Superintendent shall also be fluent or have access to a translator on site, for the primary language of all of the Workers. Degree of fluency in English and language of workers to be sufficient so that superintendent's employees can adequately and safely complete their duties:
  - 3. No employee of Contractor, Subcontractor, or Supplier may be on the Project Site who cannot be directed by a Superintendent, or translator in regards to work assignments, safety issues, or who cannot understand safety signage.



### **7.03 LABOR; WORKING HOURS**

- A. Provide equipment of sufficient size and power to expedite the project so that all deadlines are met. Personnel and crew size also shall be sufficient to meet required deadlines.
- B. If, in the sole opinion of the Engineer, there is insufficient equipment or personnel to complete the project, the Engineer will notify the Contractor and Owner, and a Project Meeting will be held within twenty-four (24) hours for the purpose of contract termination, unless a reasonable cause is given to the contrary.

### **7.05 “OR EQUALS”**

- A. Whenever an article, material, or item of equipment is described by a performance specification, written as a proprietary product, or uses the name of a manufacturer or vendor, the term “or equal” if not inserted, shall be implied. The specific article, material, or item of equipment mentioned shall be understood as indicating the minimum requirements for fulfilling contract obligations in regard to type, function, standard of design and efficiency. See Section 09 97 13, Part 2, Substitution of Coatings, which shall govern over this clause where conflicting, relative to coatings, grouts, and fillers only. Other exceptions are when the specifications state that only the proprietary item will be permitted.

### **7.11 LAWS AND REGULATIONS**

- A. Contractor is responsible for all permits and requirements of local, state, and federal agencies. This includes building, electrical, labor, OSHA, etc. The only permits not included are from health agencies for interior painting, cathodic protection installation and mixer installation which is the responsibility of the Owner.
- B. Display all wage requirements and other permits on a temporary board.
- C. Attach to the superintendent’s copy of the specifications copies of other permits that do not require display.

### **7.13 SAFETY AND PROTECTION**

- A. Conform to the Occupational Safety and Health Standards of the United States Department of Labor and local safety agencies. This shall be made a condition of each subcontract as entered into pursuant to this contract.
- B. Removal of lead based paint and painting of structures are recognized as very dangerous Work, and it is further recognized the painting industry has extensive safety training programs available.
- C. Contractor shall designate a qualified and experienced safety representative at the Site whose duties and responsibilities shall be the prevention of accidents and the maintaining and supervising of safety precautions and programs. Contractor’s Safety Representative shall have the authority to supersede Contractor’s foreman and shall stop

work if the Work being completed is in violation of Contractor's or Owner's safety program, or OSHA regulations.

- D. Monitor and be responsible for all safety practices.
- E. The Engineer and Owner shall have full access to the Site. Contractor shall make personnel and equipment available to the Owner and Engineer/RPR to expedite observations.
- F. While at the Site, Engineer's employees and representatives will comply with the specific applicable requirements of Owner's and Contractor's safety programs (if any) of which Engineer has been informed.
- G. Contractor is responsible for security, safety, etc. on the Site until all his equipment is removed and all keys are returned.

#### **7.17 CONTRACTOR'S GENERAL WARRANTY AND GUARANTEE**

- A. None of the following will constitute an acceptance of Work that is not in accordance with the Contract Documents, or a release of Contractor's obligation to perform the Work in accordance with the Contract Documents, or a release of Owner's warranty and guarantee rights:
  - 1. Observations and/or Daily Observation Reports by Engineer/RPR;
  - 2. Recommendation by Engineer or payment by Owner of any progress or final payment;
  - 3. the issuance of a certificate of Substantial Completion by Engineer or any payment related thereto by Owner;
  - 4. use or occupancy of the Work or any part thereof by Owner;
  - 5. any review and approval of a Shop Drawing or Sample submittal;
  - 6. the issuance of a notice of acceptability by Engineer;
  - 7. the end of the correction period;
  - 8. any inspection, test, or approval by others; or
  - 9. any correction of defective Work by Owner.

#### **7.19 DELEGATION OF PROFESSIONAL DESIGN SERVICES**

- A. If the Contract Documents note, or Contractor determines, that professional engineering or other design services are needed to carry out Contractor's responsibilities for construction means, methods, techniques, sequences, and procedures, or for Site safety, then Contractor shall cause such services to be provided by a properly licensed design professional, at Contractor's expense. Such services are not Owner-delegated professional design services under this Contract, and neither Owner nor Engineer has any responsibility with respect to (1) Contractor's determination of the need for such services, (2) the qualifications or licensing of the design professionals retained or employed by Contractor, (3) the performance of such services, or (4) any errors, omissions, or defects in such services.

## **ARTICLE 10 ENGINEER'S STATUS DURING CONSTRUCTION**

### **10.07 LIMITATIONS ON ENGINEER'S AUTHORITY AND RESPONSIBILITIES**

#### **A. Engineer's Responsibilities**

1. Engineer will be Owner's representative during the construction period.
2. Engineer's Project Manager (PM) will make visits to the Site at intervals appropriate to the various stages of construction as Engineer deems necessary in order to observe as an experienced and qualified design professional the progress that has been made and the quality of the various aspects of Contractor's executed Work. Based on information obtained during such visits and observations, Engineer, for the benefit of Owner, will determine, in general, if the Work is proceeding in accordance with the Contract Documents. Engineer will not be required to make exhaustive or continuous inspections on the Site to check the quality or quantity of the Work. Engineer's efforts will be directed toward providing for Owner a greater degree of confidence that the completed Work will conform to the Contract Documents. On the basis of such visits and observations, Engineer will keep Owner informed of the progress of the Work, and will endeavor to guard Owner against defective Work.
3. Engineer will identify all Set-off expenses incurred against Engineer in their invoice to Owner.
4. Engineer's review of the final Application for Payment and accompanying documentation, and all maintenance and operating instructions, schedules, guarantees, bonds, certificates of inspection, tests and approvals, and other documentation required to be delivered by Contractor, will only be to determine generally that their content complies with the requirements of, and in the case of certificates of inspections, tests, and approvals, that the results certified indicate compliance with the Contract Documents.

#### **B. The Resident Project Representative's (RPR) Responsibilities**

1. If the Owner retains Engineer to provide RPR services, the RPR will be Engineer's representative at the Site to assist in observing the progress and quality of the Work. RPR's dealings in matters pertaining to the Work in general will be with Engineer and Contractor. RPR's dealings with Subcontractors will only be through or with the full knowledge or approval of Contractor. The authority of any RPR will be as directed by the Engineer.
2. Neither Engineer's authority or responsibility under any provision of the Contract, nor any decision made by Engineer in good faith either to exercise or not exercise such authority or responsibility or the undertaking, exercise, or performance of any authority or responsibility by Engineer, will create, impose, or give rise to any duty in contract, tort, or otherwise owed by Engineer to

Contractor, any Subcontractor, any Supplier, any other individual or entity, or to any surety for or employee or agent of any of them. No Agreement between the Owner and Engineer and nothing in this Contract shall imply or construct a third party beneficiary status to the Contractor.

- C. Engineer/RPR shall have the authority to stop Work in the event continuation of Work under a noncompliance situation, such as incomplete containment, may result in the violation of environmental laws, create a potential tort, or may result in the covering of defective or unaccepted Work (Nonconformance) product. This authority to stop work transfers back to the Owner after the Owner has been notified and returns to the Site.

## **ARTICLE 11 CHANGES TO THE CONTRACT**

### **11.02 CHANGE ORDERS**

- A. A Change Order is a written order to the Contractor signed by the Owner, issued after execution of the contract, authorizing a change in the work or an adjustment in the contract sum or the contract time. The cost or credit to the Owner resulting from a change in the work shall be determined in one or more of the following ways:
  - 1. By mutual acceptance of a lump sum;
  - 2. By unit prices stated in the Contract Documents or subsequently agreed upon;
  - 3. By actual itemized cost and fixed fees as set forth in 2 above. Cost shall be limited to the following: cost of materials, cost of labor, and cost of overhead.
- B. A Bulletin will be issued in most cases before a Change Order. A Bulletin will request prices and other information from the Contractor. Prices requested in a Bulletin are subject to negotiation with the Owner.

### **11.04 FIELD ORDERS**

- A. A field modification is written by the Engineer to the Contractor for purposes of clarification of the specifications or plans. A field modification is limited to items that do not change the scope of the project.
- B. Field modifications do not affect either the project cost or completion date.
- C. Field modifications become part of the Contract Documents and become binding upon the Contractor if they fail to object within three (3) working days after receiving the modification. A field modification may be used as the basis of a project cost change or contract extension if all parties agree on the field modification form to a potential future claim of either party or that the field modification will be complied with, but under protest.

**ARTICLE 15    PAYMENTS TO CONTRACTOR; SET-OFFS; COMPLETION;  
CORRECTION PERIOD**

**15.01 AND 15.06 PROGRESS AND FINAL PAYMENTS**

- A. Engineer's review of the final Application for Payment and accompanying documentation and all maintenance and operating instructions, schedules, guarantees, bonds, certificates of inspection, tests and approvals, and other documentation required will only be to determine generally that their content complies with the requirements of, and in the case of certificates of inspections, tests, and approvals, that the results certified indicate compliance with the Contract Documents.
- B. Measurement of payment will be considered based on the Schedule of Values submitted with the Contractor's bid. The Schedule of Values will be reviewed by the Engineer prior to Notice of Award. If the Engineer determines the Schedule of Values is not acceptable, the Engineer will use the Contractor's Schedule to reallocate values. The Engineer's reallocation interest will be to maintain a sufficient value for Work completed toward the end of the project, to avoid frontloading values. The Engineer will assign values high enough to bring in another Contractor to finish Work in case of default. When evaluating the Schedule of Values, the Engineer will consider that material delivered to the Site has no value until properly applied. The Contractor has five (5) days to appeal the reallocated Schedule of Values.
- C. Pay request(s) shall be made on form(s) supplied by the Owner or Engineer or required by Owner. If no form is supplied, use AIA form.
- D. Owner will make progress payments once each month during performance of the Work, in which the Contractor files an application for payment.
  - 1. All such payments will be compared with the Schedule of Values,
  - 2. or in the case of unit price Work, based on the number of units completed, or
  - 3. if lump sum item is less than 100% completed then allocated as follows:
    - a. On the wet interior, surface preparation by abrasive blast cleaning will be considered equal to 40% of the line item Work and cost and each coat 20%.
    - b. On the exterior, surface preparation by high pressure cleaning or jetting and power tool cleaning will be considered equal to 40% of the line item Work and cost and full coat 15%. The remainder will be for lettering, demobilization, and clean-up.
    - c. Dry interior painting and repairs will not be broken down. 100% completion is required before they will be considered for payment.
    - d. Mobilization is included in the surface preparation allotment for items in 3 above.

4. Owner is entitled to impose a set-off or withholding against payment based on any of the following:
  - a. Third party claims, have been made or there is reasonable evidence indicating probable filing of claims against Owner on account of Contractor's conduct in the performance or furnishing of the Work, or
  - b. Owner has incurred costs, losses, or damages on account of Contractor's conduct in the performance or furnishing of the Work, including but not limited to claims, costs, losses, or damages from Workplace injuries, adjacent property damage, non-compliance with Laws and Regulations (Special Damages, see Article 18 below), and patent infringement or,
  - c. Damage caused by the Contractor to the Owner or to another Site approved Contractor or;
  - d. Contractor has failed to take reasonable and customary measures to avoid damage, delay, disruption, and interference with other Work at or adjacent to the Site or;
  - e. an event that would constitute a default by Contractor and therefore justify a termination for cause or;
  - f. defective Work not remedied;
    - i. requiring correction or replacement including additional inspection costs
    - ii. requiring correction or replacement
    - iii. Owner has been required to correct defective Work or
    - iv. has accepted defective Work
  - g. persistent failure to carry out the Work in accordance with the Contract Documents.
  - h. Owner has been required to remove or remediate a Hazardous Environmental Condition for which Contractor is contractually responsible or responsible for creating the condition;
  - i. the Contract Price has been reduced by Change Orders;
  - j. failure of the Contractor to make payments properly to subcontractors, or for labor, materials, or equipment or;
  - k. liens have been filed in connection with the Work, except where Contractor has delivered a specific bond satisfactory to Owner to secure the satisfaction and discharge of such Liens;
  - l. liquidated damages have accrued as a result of Contractor's failure to achieve Milestones, Substantial Completion, or Ready for Final Payment or;
  - m. reasonable evidence that the Work cannot be completed for the unpaid balance of the contract sum, or within the contract time or;
  - n. Contractor has failed to provide and maintain required bonds or insurance or;

- o. Engineer has actual knowledge of the occurrence of any of the events that would constitute a default by Contractor and therefore justify termination for cause under the Contract Documents.
  - p. Owner has incurred extra charges or Engineering costs related to submittal reviews, evaluations of proposed substitutes, tests and inspections, or return visits to complete field observations that were determined to be failed;
  - q. other items entitling Owner to a Set-off against Payment
  - r. The Owner may also decline to make payment including an item previously approved for payment, because of subsequently discovered evidence or subsequent observations, as may be necessary in their opinion to protect against loss by Set-off amount previously recommended.
5. If Owner imposes any set-off against payment, whether based on its own knowledge or on the written recommendations of Engineer, Owner will give Contractor immediate notice (with a copy to Engineer) stating the reasons for such action and the specific amount of the reduction, and promptly pay Contractor any amount remaining after deduction of the amount so withheld. Owner shall promptly pay Contractor the amount so withheld, or any adjustment agreed to by Owner and Contractor, if Contractor remedies the reasons for such action.
- a. The reduction imposed shall be binding on Contractor unless Contractor duly submits a Change Proposal contesting the reduction.
  - b. Engineer will recommend reductions in payment (set-offs) necessary in Engineer's opinion to protect Owner from loss.
6. Owner may decide against Set-off as a remedy, but in so doing, Owner does not waive any remaining remedies.
7. Neither the Owner nor the Engineer are under any requirements or obligations to notify the bonding company at project conclusion of Set-offs or other remedies chosen.
8. If the Owner/Engineer prepare an accounting Change Order at Project Conclusion it will be considered signed by Contractor, unless the Contractor files a Change Proposal within five days protesting the Set-off. If appeal is rejected, the Change Order will be considered signed unless further appeals per the appeals process are claimed.

#### **15.08 CORRECTION PERIOD**

- A. Within thirteen (13) months from the date of substantial completion, the structure will be inspected by the Owner and/or their representative.
- B. The inspection will be performed in accordance with the applicable portions of AWWA D-102-17 Standard for Painting Steel Water Storage Tanks and industry standards.
- C. The Owner will establish a date of inspection and may or may not notify the Contractor in advance. The Contractor's attendance will not be required.

- D. The Owner will select a third party inspection firm (either Engineer or project representative) to document inspection.
- E. Any failed Work will be documented and the Contractor will be notified of necessary repair (method and extent). The Owner reserves the right to require inspection of the repair Work and possibly a second warranty inspection, dependent on degree of failure.
- F. This warranty will automatically be extended until the tank is ice-free (if applicable) and the warranty inspection can be performed. The Contractor guarantees that the system is free from defects due to faulty materials or Workmanship and the Contractor shall make the necessary correction to correct these defects. If the amount of rework exceeds ten percent (10%) of a portion of the project, then the Owner reserves the right to have the warranty period extended one (1) year for the entire portion of the Work.
- G. Cost for one (1) year warranty inspection will be the responsibility of the Owner.
- H. Cost for a second warranty inspection and repair inspections will be the responsibility of the Contractor and guaranteed by Contractor's Performance and Maintenance Bond (see Article 6)
- I. The Owner retains all contractual remedies. The warranty shall not be considered an exclusive remedy.
- J. If the Owner conditionally accepts Work which was observed or found to be in noncompliance, then the Owner has the right to withhold from final payment an amount equal to the cost to redo the Work if it fails the subsequent Warranty Observation, as well as an additional amount for additional Engineering services.
- K. Contractor shall pay for additional expenses for RPR or Engineering or other Owner related expenses resulting from the failed Warranty. The Maintenance Bond shall remain in full effect, but Engineer will notify Contractor first. Failure to respond positively within two weeks will trigger notification and claim to bonding company.

## **ARTICLE 16      SUSPENSION OF WORK AND TERMINATION**

### **16.02 AND 16.03 TERMINATION for CAUSE AND FOR CONVENIENCE**

- A. The Owner may terminate the contract when the approved progress schedule is not met because of failure of the Contractor to exercise diligence and effectively perform all required work, or when the progress of the work is unacceptable to the owner.
- B. In the absence of a project Progress Schedule, the determination regarding the Contractor's diligence will be based on the Engineer's opinion, correspondence, and field reports.
- C. The Owner may terminate the contract when in the opinion of the Engineer the Non-conformance report(s) indicate the Contractor is unable or unwilling to complete the contract within the terms of the contract.



## **ARTICLE 18 MISCELLANEOUS**

### **18.02 LIMITATION OF DAMAGES**

- A. Contractor shall reimburse Owner (1) for any fines or penalties imposed on Owner as a direct result of the Contractor's failure to attain Substantial Completion according to the Contract Times, and (2) for the actual costs reasonably incurred by Owner for Engineering, construction observation, inspection, and administrative services needed after the time specified in the Project Summary for Substantial Completion (as duly adjusted pursuant to the Contract), until the Work is substantially complete.
- B. After Contractor achieves Substantial Completion, if Contractor shall neglect, refuse, or fail to complete the remaining Work within the Contract Times, Contractor shall reimburse Owner for the actual costs reasonably incurred by Owner for Engineering, construction observation, inspection, and administrative services needed after the time specified in Paragraph 4.02 for Work to be completed and ready for final payment (as duly adjusted pursuant to the Contract), and if necessary to hire other Contractors to complete portions of the Work, until the Work is completed and ready for final payment.
- C. The special damages imposed in this paragraph are supplemental to any liquidated damages for delayed completion established in this Agreement.

## **SECTION 00 91 18**

### **DEFINITIONS for TECHNICAL SPECIFICATIONS**

#### **PART 1 – GENERAL**

##### **1.01 DEFINITIONS FOR TECHNICAL SPECIFICATIONS**

- A. Wet Interior: Internal surfaces, excluding inaccessible areas, to the roof, shell, bottom, accessories, and appurtenances that are exposed to the stored water or its vapor. Examples are the interior of the roof, sidewall, bowl and riser and exterior of the access tube within the tank.
- B. Dry Interior: Surfaces of the finished structure, excluding inaccessible areas, that are not exposed to the elemental atmosphere or the stored water or its vapor. Examples are the interior of the access tube and interior of the access leg.
- C. Exterior: External surfaces, excluding inaccessible areas, of the roof, sidewall, riser, legs, accessories, and appurtenances that are exposed to the elemental atmosphere.
- D. Inaccessible Areas: Areas of the finished structure that, by virtue of the configuration of the completed structure, cannot be accessed to perform surface preparation or coating application (with or without the use of scaffolding, rigging, or staging). Inaccessible areas include such areas as the contact surfaces of roof plate lap joints, underside of roof plates where they cross supporting members, top surface of rafters directly supporting roof plates, contact surfaces of bolted connections, underside of column baseplates, contact surfaces of mating parts not intended to be removed or disassembled during routine operation or maintenance of the structure and inside of risers less than a nominal 36 in. diameter.
- E. Sidewall: Vertical walls to the weld seam of the roof.
- F. Access Tube: Cylindrical tube extending from top of the riser to the roof through the tank, including all steel appurtenances (i.e. ladder, overflow pipe, brackets, etc.)
- G. Roof: Very top of the structure, including top seam of sidewall.
- H. Bottom: Lower area of the tank proper shaped like a bowl.
- I. Riser: Center support.
- J. Tower Structure: Multi-legged system used to support the elevated tank consisting of legs, struts, rods, connections, anchors, etc.

**SECTION 00 91 19.01**  
**SCHEDULING FOR RPR SERVICES**

**PART 1 – COMMUNICATION**

**1.01 RESIDENT PROJECT REPRESENTATIVE (RPR) SERVICES**

- A. DIXON provides three types of RPR services or any combination of the three:
1. Hold Point Site Visits (sometimes called Critical Phase Visits) where RPR Services are for defined Hold Point, where Work stops until that portion of Work is reviewed on Site by a professional RPR.
  2. Full Time RPR is a professional RPR staying in lodging away from home and living on per diem expenses.
  3. Daily RPR is a professional RPR living at home and traveling to Site on a daily basis.
  4. Based on the type of project the RPR services may change from Daily or Full Time to Hold Point or from Hold Point to Daily or Full Time.
  5. Intended Beneficiary: The onsite observation services for this project are for the benefit of the Owner. There are no intended benefits to the contractor, or any other third parties. Contractor still provides quality control (QC).

**1.02 HOLD POINT OBSERVATIONS AND MEETINGS**

- A. Each hold point requires an onsite visit for Observation. Example: If the contractor coats over or otherwise makes work inaccessible for Observation, the Work will be considered failed. Remove Work and recoat or repair in accordance with this specification. At least two (2) new hold points, surface preparation and coating, may be created when work fails after the primer has been applied.
- B. Stop Work and schedule Observation times for the following Hold Points as a minimum. Additional Hold Points may be determined at the Preconstruction Meeting. Each Hold Point requires a Site visit and observation. Schedule of Hold Points – Preliminary:
1. Hold Point Meeting: The Preconstruction Meeting is the initial hold Point. The Preconstruction Meeting will not be scheduled until five (5) days after all required submittals are received and reviewed by the Engineer and no exceptions are taken to the shop drawings.
  2. Hold Point - Prior to draining tank:
    - a. To ensure all Section of 01 50 00 and 01 53 43 environmental requirements are met.
    - b. To ensure ventilation, decontamination, and blasting equipment are on-site and in working order.
  3. Hold Points – 03 01 30 Maintenance of Cast-in-place Concrete.
    - a. To locate or quantify repairs as necessary.

- b. To review surface preparation prior to concrete or grout installation and review all products prior to installation.
- c. After concrete or grout application is complete for quality assurance.
- 4. Hold Points – Section 05 00 00 – Metal Repairs:
  - a. To locate or quantify repairs as necessary.
  - b. To review surface preparation prior to welding and review all products prior to installation.
  - c. After welding is complete for quality assurance.
- 5. Hold Points – Sections 09 97 13 – Steel Coating and 09 97 13.10 Steel Coating Surface Preparation:
  - a. Prior to surface preparation to set the standard.
  - b. Prior to primer application to verify cleanliness, profile, thoroughness, and ambient conditions for coating application.
  - c. Prior to application of each successive coat for quality assurance and ambient conditions for the next coat.
  - d. Prior to final coat to verify all non-conformance issues have been resolved.
  - e. Scheduled pre-final Observation: Allow engineer access to all locations so a complete punch list can be prepared. Final coat on ladders or other access points can be delayed until after this Observation and included as a punch list item.
  - f. Scheduled final Observation: After ALL punch list items have been completed (including painting ladders), provide access to all items on the punch list.

### **1.03 SCHEDULING FOR RPR SERVICES FOR HOLD POINT OBSERVATIONS**

- A. Prior to First Observation 48 hours advance Notice is required
- B. All Subsequent Hold Points shall be scheduled by 6:00 P.M (Eastern Time) the previous day.
  - 1. Scheduling with a Central Contract Administrator. Names and phone numbers of a Contract Administrator and a Second Contract Administrator will be given to the Contractor during the Preconstruction Meeting.
- C. The Contract Administrator may be contacted by cell phone. If no answer a voice mail may be left with all details of RPR request included, or
- D. The Contract Administrator may be contacted by text to their cell phone.
- E. If the Contract Administrator is not available, DIXON's Corporate Office may be contacted during regular working hours at 1-800-327-1578.
- F. Scheduling through a Project Manager is not an alternative.
- G. Scheduling through an RPR is not an alternative for Hold Point Observation.

#### **1.04 SCHEDULING FOR RPR SERVICES FOR FULL TIME OF DAILY OBSERVATIONS**

##### **A. Productive Work**

1. Do not start, continue, or complete any Productive Work if RPR is not present on the project site.
2. Productive Work includes, but is not limited to, all elements of abrasive blast cleaning, power washing, high pressure water jetting or high/low pressure water cleaning, power tool cleaning, rigging, painting, metal repairs, concrete repairs, punch list items, and clean-up.
3. Preparation, mobilization, and containment erection, and other non-productive work does not require observation if completed before the structure is removed from service, nor does demobilization after tank is returned to service.
4. But if containment erection is completed while other productive work progresses, an RPR is required.
5. If welding is completed for contracted work (antenna rails, painter's rails, ladders, etc.) during containment erection welding, then contracted work is considered Productive Work and an RPR shall be present. Any spot painting during containment erection is also considered Productive Work.
6. After the project has been completed and after all punch list items have been completed, cure time and site clean-up, excluding any waste coating or abrasive issues, are not considered Productive Work.
7. After the Project has been completed; complaints from Owner or neighbors concerning health, environmental, or damage issues, or if there are still waste coating or waste abrasive issues, these are considered Productive Work requiring an RPR even after the structure is returned to service.
8. Essentially all work completed between out-of-service date and Substantial Completion Date, excluding cure and disinfection, is considered Productive Work and requires the presence of an RPR.

#### **1.05 SCHEDULING WITH A CENTRAL CONTRACT ADMINISTRATOR**

- A. The Contract Administrator may be contacted by cell phone. If no answer a voice mail may be left with all details of RPR request included or
- B. The Contract Administrator may be contacted by text to their cell phone.
- C. If the Contract Administrator is not available DIXON's Corporate Office may be contacted during regular working hours at 1-800-327-1578.
- D. Scheduling through a Project Manager is not an alternative.

#### **1.06 SCHEDULING THROUGH ONSITE RPR**

- A. Scheduling through on site RPR completing Full Time or Daily RPR Services may be considered a properly completed Request if completed by the foreman and RPR

before leaving site. If not completed on site then schedule through the Central Contract Administrator.

**1.07 SUMMARY OF SCHEDULING HOLD POINT OBSERVATIONS**

- A. Contract Administrator
  - 1. by phone
  - 2. by text
  - 3. by voice mail
- B. Second Contract Administrator
  - 1. by phone
  - 2. by text
  - 3. by voice mail
- C. Corporate Office during work hours
  - 1. by phone
  - 2. NO voicemail
- D. Do NOT contact Project Manager

**1.08 SUMMARY OF SCHEDULING FOR FULL TIME OR DAILY OBSERVATIONS**

- A. Contract Administrator
  - 1. by phone
  - 2. by text
  - 3. by voice mail
- B. Second Contract Administrator
  - 1. by phone
  - 2. by text
  - 3. by voice mail
- C. Corporate Office during work hours
  - 1. by phone
  - 2. NO voicemail
- D. RPR on site
- E. Do NOT contact Project Manager

**1.09 CONTRACTOR'S RESPONSIBILITIES**

- A. The Engineer and Owner shall have full access to the Site at reasonable times for their Observation, testing, and Contractor's personnel and equipment shall be available to the Owner and Engineer/RPR to expedite Observations. Provide Owner, Engineer/RPR proper and safe conditions for such access, including rigging, and advise them of contractor's site safety procedures and programs so that they may comply as applicable.
- B. Contractor is responsible for all of Contractor's manpower needs and scheduling and Work to be completed. RPR is to be available to expedite the project and complete

- their services with minimal interference of the Contractor's Work. Successful project completion is dependent on Contractor's proper scheduling and use of RPR services.
- C. Contractor is financially responsible for efficient scheduling of RPR services, See Section 00 91 19.02.

#### **1.10 DELAY IN ARRIVAL OF RPR**

- A. RPRs for Hold Point, Full – Time or Daily observations may be delayed by traffic or other reason from arriving at the scheduled time. Contractor shall contact Contract Administrator immediately if the RPR has not arrived at the scheduled time.
- B. The Contract Administrator will locate the missing RPR, return to the Contractor with a revised arrival time, and discuss with Contractor what other Work can be completed until RPR arrives for Observation.

#### **1.11 REJECTED DEFECTIVE WORK**

- A. All Productive Work completed without an RPR present shall be considered Defective Work and rejected per the General Conditions. This includes Work completed:
1. Without proper scheduling an RPR
  2. Prior to the scheduled arrival of the RPR
  3. When Day has been scheduled as a No Workday
  4. When RPR is delayed and Contract Administrator has not been notified.

#### **1.12 NON-CONFORMANCE REPORTS (NCR)**

- A. The RPR will issue a non-conformance report for every performance item, material, or equipment supplied, and/or environmental situation that fails to meet requirements of the specifications.
- B. All Work in non-conformance will be considered Defective Work to be replaced, repaired per terms of the General Conditions.
- C. Do not start Work until all required equipment and RPR is on-site.
- D. Immediately correct all environmental non-conformance to prevent an accident. If an incident has already occurred, contact the proper governmental environmental agency and conduct an immediate clean-up per their direction.
- E. If the Nonconformance is issued because of equipment specified but not delivered, repaired or replaced then the financial Set-off will be 140% \* of the rental value of equipment in non-conformance (i.e. non-working decontamination trailer, hand wash facilities, are filtration units, etc.).
- F. If the Nonconformance issued is because of noncompliance with environmental equipment or practices the Set-off will be 140%\* of the estimated cost of compliance. \*The costs of items E. and F. above are damage estimates. The cost of equipment will be the rental charge from a reputable local dealer with 40% extra being for operation cost. Cost of environmental compliance is the estimated cost of

compliance. The extra 40% is potential risk to the owner for non-conformance. In no situation will the Owner assume liability.

- G. All additional Engineering/RPR expenses incurred because of a nonconformance report is subject to Set off by Owner.



## **SECTION 00 91 19 .02**

### **CONTRACTOR'S FINANCIAL RESPONSIBILITY FOR RPR**

#### **PART 1 - PROGRESS SCHEDULE and RPR SCHEDULE**

##### **1.01 GENERAL**

A. Contractor is financially responsible for the proper and efficient use of RPR services.

##### **1.02 PROGRESS SCHEDULE**

- A. Per the General Conditions a Progress Schedule is required to be submitted. At the Preconstruction meeting the Contractor shall submit a preliminary Progress Schedule. This General Conditions of this contract as-bid restricts Work to 40 hours/ 8 hours per day, 5 days per week. If the Owner has prior approved a more open schedule it is noted in the Project Summary. Either prior approved in the Project Summary or not; a Progress Schedule more aggressive than Monday through Friday, regular working hours, will require submittal and discussion, at Preconstruction Meeting.
- B. Once the Owner, at the Preconstruction meeting accepts a more aggressive schedule the Contractor is responsible for all of the Contractor's manpower scheduling and Critical Path Work to maintain the Schedule.
- C. Contractor shall complete a minimum 8 hours per day of Productive Work, which should be calculated into the Schedule.

##### **1.03 HOLD POINTS AND RPR SERVICES**

- A. Fees for Hold Point RPR Services are contracted with the Owner at a Unit Price and are calculated to include the following: travel time to and from Site, reimbursable expenses, observation and report time. Time required for Contractor to repair or redo small areas that failed Observation, are not included in the unit price. Failure may be minimal compared to all Work observed, but failed Work still must be observed before proceeding. For minor failures that can be quickly repaired, the Contractor may entirely at their option:
1. Accept a Non-Conformance for failed Observation.
  2. Request, the RPR wait for a reasonable period while repairs are completed.
  3. Proceed with the next phase for all areas which have not failed, and "work around" failed areas. The failed areas would then be observed at the next Hold Point.
- B. The Fee for extended onsite time, or a new Hold Point is the responsibility of the Contractor.

##### **1.03.1 FULL TIME OR DAILY RPR SERVICES**

- A. It is the intention of the Owner, that the RPR fees be used to observe Productive Work. Productive Work is defined in previous Section 00 91 19 .01 Scheduling for RPR Services, with examples. The Owner will pay for all RPR service fees generated observing Productive Work that meets specification requirements. Normally this will be the first time for most observations. But if Observation fails, then the Owner pays for second observation, if it passes.

- B. The Contractor will pay all RPR and/or Engineer fees generated by failed Observations of Productive Work.
- C. Availability of RPR and RPR's ability to timely perform the required Services are dependent on Contractor's communication. RPR is to be available to meet the Progress Schedule demands and complete RPR services with minimal interference of the Contractor's Work, if Contractor properly scheduled RPR Services.

### **1.03.2 FULL TIME OR DAILY RPR SERVICES**

- A. Contractor Pays for RPR or Engineering Services resulting from:
  - 1. Productive Work on a Holiday
  - 2. Failed or Improper Scheduling,
  - 3. Failure to Request Observation per Section 00 91 19 .01,
  - 4. Less than 8 hours per day or On-Call Time as a result of:
    - a. Premature Request for RPR Services,
    - b. No show or late start,
    - c. Rejection of Work and/or Non-Conformance reports,
    - d. Equipment failure, insufficient manpower, materials or equipment
    - e. Weather reasons per 1.04.B.03

### **1.04 RPR FEE CALCULATIONS FOR FAILED OBSERVATIONS**

- A. The basis for Fees assessed to Contractor is based on the Owner/DIXON contract. Fees will be calculated in the same manner as in Owner/Engineer Agreement, i.e. if the RPR is working at an overtime rate for Owner, then fee for unproductive services will be documented at the same rate
  - 1. Hold Point for Welding or Coating Observation, or extra Progress Meetings
    - a. The same Unit Price Fee as would be charged to Owner for each respective Observation or meeting. Note the fee will be determined by the Contract and may vary between types of Hold Point services.
    - b. Extended time at site charged at Regular Rate (See definition below)
  - 2. Daily Observation shall be the same fee as charged to Owner from the Owner/DIXON contract.
    - a. Minimum workday is 8 hours plus travel time
    - b. reimbursable mileage
  - 3. Fulltime Observation Fee shall be the same as charged to Owner for the same Service.
    - a. Minimum workday is 8 hours
    - b. Minimum work week is 40 hours
    - c. Reimbursable expenses/ Per Diem
  - 4. Fees common to Full Time, Daily and Hold Points with extended stays, and On-Call Time
    - a. Regular Pay for RPR is charged at the rate matching the RPR's experience and qualifications.
    - b. Overtime Rate is 1.5 times Regular Rate
      - 1) For all time worked on the actual holiday
      - 2) Weekend work by RPR

- 3) For time over 40 hours. (The standard work week for overtime (over 40) begins on Monday as Sunday is already paid at overtime rate.)
- B. Fees of misused or unnecessary Engineer/RPR Services will be documented and submitted to the Owner for Set off.
- C. The right to Set-off is a contracted right of Owner per the General Conditions, or Additions to General Conditions, and the right to enforce those rights are at the Owner's discretion.

#### **1.05 ON-CALL TIME**

- A. RPR's are professional personnel that get paid a minimum of 8 hours per day even though the Contractor's operations or methods results in less than an 8 hour day.
- B. If the Contractor has scheduled a Workday, and if RPR is not free to spend the day at RPR's discretion or to be reassigned; then the RPR will be considered On-Call.
  1. The RPR will be considered, if scheduled, on-call every morning and day unless work is cancelled per Section 00 19 91.01.
  2. For Daily observation the On - Call time will not exceed 8 hours, any travel time should occur within that 8 hours.
    - a. Late Starts - Agreed start time will be scheduled with the Contract Administrator at the Preconstruction Meeting.
    - b. The RPR's on-call time starts at the agreed start time, if RPR is on Site and available to Work, and On Call time continues until Work starts.
  3. For weather reasons
    - a. 8 hours if adverse weather conditions were clearly forecast
    - b. Two hours plus time worked up to 8 hours or actual time worked if greater; if forecast was less than 20% weather meeting definition of a weather day.
  4. For reasons other than weather, eight (8) hours will be considered minimum On-Call Time. This includes, but is not limited to, equipment failure, insufficient materials, damaged containment, etc.
- C. Actual charged on-call time will be eight (8) hours, minus the number of hours actually worked.
- D. Overtime, Weekend, Holiday pay requirements apply to all on-call time pay. On-call hours will count towards forty (40) hour week triggering overtime at forty (40) hours.
- E. If Work is cancelled per requirements in Section 00 19 91.01 (by prior night) in advance and RPR is notified in advance, there is no on call time.
- F. If contractor schedules days off per Scheduling requirements, the inspector will return to his/her home base and there will be no show time charges. Based on the Contract the RPR may be entitled to Mobilization or Demobilization.

## **SECTION 01 50 00**

### **TEMPORARY CONSTRUCTION FACILITIES and UTILITIES**

#### **PART 1 - GENERAL**

##### **1.01 SUMMARY**

- A. The Contractor is fully responsible to provide and maintain temporary facilities and utilities required for construction as described herein, and to remove the same upon completion of work.

##### **1.02 QUALITY ASSURANCE**

- A. Regulatory Requirements:
  - 1. National Fire Protection Association (NFPA): NFPA No.70-93
  - 2. National Electrical Code (NEC) and local amendments thereto.
  - 3. Comply with any and all federal, state, and local codes and regulations, and utility company requirements.

#### **PART 2 - PRODUCTS**

##### **2.01 TEMPORARY ELECTRICITY and LIGHTING**

- A. Supply temporary lighting sufficient to enable Contractor to safely access all work areas.
- B. Electrical requirements in excess of capacity of existing electrical service shall be responsibility of Contractor.
- C. Provide, maintain, and remove temporary electric service facilities.
- D. Facilities exposed to weather shall be weatherproof-type and electrical equipment enclosure locked to prevent access by unauthorized personnel.
- E. Contractor is to pay for and arrange for the installation of temporary services.
- F. Patch affected surfaces and structures after temporary services have been removed.
- G. Provide explosion proof lamps, wiring, switches, sockets, and similar equipment required for temporary lighting and small power tools.

##### **2.02 WATER for CONSTRUCTION**

- A. Owner will provide water required for cleaning and other purposes.
- B. Water use shall not exceed usage that might endanger the Owner's water system's integrity.

##### **2.03 SANITARY FACILITIES**

- A. Provide temporary sanitary toilet facilities conforming to state and local health and sanitation regulations, in sufficient number for use by Contractor's employees.

- B. Maintain in sanitary condition and properly supply with toilet paper.
- C. Remove from site before final acceptance of work.

#### **2.04 TEMPORARY FIRE PROTECTION**

- A. Provide and maintain in working order a minimum of two fire extinguishers and such other fire protective equipment and devices as would be reasonably effective in extinguishing fires.

#### **2.05 DAMAGE to EXISTING PROPERTY**

- A. Contractor is responsible for replacing or repairing damage to existing buildings, sidewalks, roads, parking lot surfacing, and other existing assets.
- B. Owner has the option of contracting for such work and having cost deducted from contract amount if the Contractor is not qualified to complete repairs, or fails to act in a timely manner.

#### **2.06 SECURITY**

- A. Security is not provided by Owner.
- B. Contractor shall be responsible for loss or injury to persons or property where work is involved, and shall provide security and take precautionary measures to protect Contractor's and Owner's interests.

#### **2.07 TEMPORARY PARKING**

- A. Parking for equipment and Contractor employees shall be designated and approved by Owner.
- B. Make arrangements for parking area for employees' vehicles.
- C. Any costs involved in obtaining parking area shall be borne by Contractor.

### **PART 3 - EXECUTION**

#### **3.01 GENERAL**

- A. Maintain and operate systems to ensure continuous service.
- B. Modify and extend systems as work progress requires.

#### **3.02 REMOVAL**

- A. Completely remove temporary materials and equipment when no longer required.
- B. Clean and repair damage caused by temporary installation or use of temporary facilities.
- C. Restore existing or permanent facilities used for temporary service to specified or original condition.

### **3.03 BARRIERS and ENCLOSURES**

- A. The Contractor shall furnish, install, and maintain as long as necessary, required adequate barriers, warning signs or lights at all dangerous points throughout the work for protection of property, workers, and the public. The Contractor shall hold the Owner harmless from damage or claims arising out of any injury or damage that may be sustained by any person or persons as a result of the work under the contract.

**SECTION 01 53 43**  
**PROTECTION of ENVIRONMENT**

**PART 1 - GENERAL**

**1.01 SUMMARY**

- A. Contractor in executing work shall maintain work areas, on-and-off site, free from environmental pollution that would be in violation of federal, state, or local regulations.
- B. The Contractor is responsible for any and all clean-up that may be necessary and all applicable costs for the same.

**1.02 LAWS and REGULATIONS**

- A. Environmental regulations may be met with different available technologies. It is the Contractor's sole responsibility to comply with these and all applicable environmental regulations.
- B. If a contamination occurs work will stop until cleanup is complete.

**1.03 PROTECTION of SEWERS**

- A. Take adequate measures to prevent impairment of operation of existing sewer system. Prevent construction material, pavement, concrete, earth, or other debris from entering sewer or sewer structure.

**1.04 PROTECTION of WATERWAYS**

- A. Observe rules and regulations of local and state agencies, and agencies of U.S. government prohibiting pollution of any lake, stream, river, or wetland by dumping of refuse, rubbish, dredge material, or debris therein.
- B. Provide containment that will divert flows, including storm flows and flows created by construction activity, to prevent loss of residues and excessive silting of waterways or flooding damage to property.
- C. Comply with procedures outlined in U.S. EPA manuals entitled "Guidelines for Erosion and Sedimentation Control Planning and Implementation," Manual EPA-72-015 and "Processes, Procedures, and Methods to Control Pollution Resulting from all Construction Activity," Manual EPA 43019-73-007.

**1.05 DISPOSAL of EXCESS EXCAVATED and OTHER WASTE MATERIALS**

- A. Dispose waste material in accordance with federal and state codes, and local zoning ordinances.

- B. Unacceptable disposal sites include, but are not limited to, sites within wetland or critical habitat, and sites where disposal will have detrimental effect on surface water or groundwater quality.
- C. Make arrangements for disposal subject to submission of proof to Engineer that Owner(s) of proposed site(s) has valid fill permit issued by appropriate government agency and submission of haul route plan, including map of proposed route(s).
- D. Provide watertight conveyance for liquid, semi-liquid, or saturated solids that have potential to leak during transport. Liquid loss from transported materials is not permitted, whether being delivered to construction site or hauled away for disposal. Fluid materials hauled for disposal must be specifically acceptable at selected disposal site.

#### **1.06 PROTECTION of AIR QUALITY**

- A. Contain paint aerosols and VOCs by acceptable work practices.
- B. Minimize air pollution by requiring use of properly operating combustion emission control devices on construction vehicles and equipment used by Contractor, and encouraging shutdown of motorized equipment not actually in use.
- C. Trash burning not permitted on construction site.
- D. If temporary heating devices are necessary for protection of work, they shall not cause air pollution.

#### **1.07 PROTECTION from FUEL and SOLVENTS**

- A. Protect the ground from spills of fuel, oils, petroleum distillates, or solvents by use of containment system.
- B. Total paint, thinner, oils, and fuel delivered to and stored on-site cannot exceed supplied capacity of spill containment provided (i.e. fuel and oil to be sized to exceed possible spill).
- C. Provide proper containment unit under fuel tank and oil reservoirs for all equipment and fuel storage tanks.
- D. Barrels of solvents, even for cleaning, are prohibited. Do not deliver paint thinners in containers greater than five (5) gallons.
- E. Disposal of waste fluids shall be in conformance with federal, state, and local laws and regulations.

#### **1.08 USE of CHEMICALS**

- A. Chemicals used during project construction or furnished for project operation, whether herbicide, pesticide, disinfectant, polymer, reactant, or of other classification, must show approval of U.S. EPA, U.S. Department of Agriculture, state, or other applicable regulatory agency.



- B. Use of such chemicals and disposal of residues shall be in conformance with manufacturer's written instructions and applicable regulatory requirements.

**1.09 NOISE CONTROL**

- A. Conduct operations to cause least annoyance to residents in vicinity of work and comply with applicable local ordinances.
- B. Equip compressors, hoists, and other apparatus with mechanical devices necessary to minimize noise and dust. Equip compressors with silencers on intake lines.
- C. Equip gasoline or oil-operated equipment with silencers or mufflers on intake and exhaust lines.
- D. Route vehicles carrying materials over such streets as will cause least annoyance to public and do not operate on public streets between hours of 6:00 P.M. and 7:00 A.M., or on Saturdays, Sundays, or legal holidays unless approved by Owner.

**PART 2 - PRODUCTS**

(Not Applicable)

**PART 3 - EXECUTION**

**3.01 HAZARDOUS MATERIALS PROJECT PROCEDURES**

- A. Applicable Regulations:
  - 1. RCRA, 1976 – Resource Conservation and Recovery Act: This federal statute regulates generation, transportation, treatment, storage and disposal of hazardous wastes nationally.
  - 2. Act 64, 1979 – Michigan's Hazardous Waste Management Act: This statute regulates generation, transportation, treatment, storage, and disposal of hazardous wastes.
  - 3. Act 641 as amended 1990 – Michigan's Solid Waste Act: This statute regulates generation, transportation, treatment, storage and disposal of solid wastes.
- B. Use the Uniform Hazardous Waste Manifest (shipping paper) to use an off-site hazardous waste disposal facility.
- C. Federal, State and local laws and regulations may apply to the storage, handling and disposal of hazardous materials and wastes. The list below includes the regulations which are most frequently encountered:

<u>Topic</u>	<u>Agency and Telephone Number</u>
Small quantity hazardous waste management, including hazardous waste stored in tanks	Hazardous Waste Division, EGLE (517) 373-2730 in Lansing, or District Office Certified County Health Department

Hazard Communication Standards  
(for chemical in the workplace)

Occupational Health Division,  
Michigan Department of Consumer  
and Industrial Services (517) 373-  
1410

Burning of waste oil and other  
discharges to the air

Air Quality Division, EGLE (517)  
322-1333 in Lansing, or District  
Office

Local fire prevention regulations and  
codes (including chemical storage  
requirements)

Local fire chief or fire marshal

D. Department of Environment, Great Lakes, and Energy  
Hazardous Waste Division  
Compliance Section District Offices

Grand Rapids District Office  
State Office Building - 5<sup>th</sup> Floor  
350 Ottawa Ave. – Unit 10  
Grand Rapids, MI 49503  
(616) 356-0500  
(616) 356-0202 (fax)

**SECTION 03 01 30**  
**MAINTENANCE OF CAST-IN-PLACE CONCRETE**

**PART 1 – GENERAL**

**1.01 SECTION INCLUDES**

- A. Repair of deteriorated and damaged concrete.

**1.02 RELATED DOCUMENTS**

- A. General provisions of the Contract, including General and Supplementary Conditions apply to this Section.

**1.03 REFERENCES**

- A. Codes, specifications, and standards referred to by number or title shall form a part of this specification to the extent required by the references thereto. Latest revisions shall apply in all cases.
  - 1. “Building Code Requirements for Structural Concrete (ACI 318) and Commentary (ACI 318R),” American Concrete Institute.

**1.04 WORK INCLUDED**

- A. Repair foundation spalls.

**1.05 PREINSTALLATION MEETINGS**

- A. Preinstallation Conference: Conduct conference at Project site.
  - 1. Review methods and procedures related to concrete maintenance including, but not limited to, the following:
    - a. Verify concrete-maintenance specialist's personnel, equipment, and facilities needed to make progress and avoid delays.
    - b. Materials, material application, sequencing, tolerances, and required clearances.
    - c. Quality-control program.
- B. Contractor shall notify engineer a minimum of twenty-four hours before placing concrete or grout repair material.
- C. Do not place any repair material until surface preparation has been reviewed and approved by engineer.

**1.06 SUBMITTALS**

- A. Submit the following ten (10) days prior to the preconstruction meeting:
  - 1. Safety Data Sheets (SDS) and Product Data Sheets:

- a. Furnish from all suppliers Safety Data Sheets and product data sheets for all applicable materials including, but not limited to, concrete, grouts admixtures, sealers.
- b. Provide for employees one (1) copy of all data sheets at the job site for employee access.
- c. Provide one (1) hard copy and an electronic copy to the engineer.
- d. No work may commence without the complete filing. All SDS shall conform to requirements of SARA (EPCRA) Right-to-Know Act.

#### **1.07 QUALITY ASSURANCE**

- A. Manufacturer Qualifications: Each manufacturer shall employ factory-authorized service representatives who are available for consultation and Project-site inspection and on-site assistance.

#### **1.08 PRODUCT DELIVERY, STORAGE AND HANDLING**

- A. Comply with manufacturer's written instructions for minimum and maximum temperature requirements and other conditions for storage.
- B. Store cementitious materials off the ground, under cover, and in a dry location.
- C. Store aggregates covered and in a dry location; maintain grading and other required characteristics and prevent contamination.
- D. Promptly remove damaged or unsuitable products from the job site. Replace products with undamaged, suitable products.

#### **1.09 FIELD CONDITIONS**

- A. Cold-Weather Requirements for Cementitious Materials: Do not apply unless concrete-surface and air temperatures are above 40 deg F (5 deg C) and will remain so for at least 48 hours after completion of Work.
- B. Hot-Weather Requirements for Cementitious Materials: Protect repair work when temperature and humidity conditions produce excessive evaporation of water from patching materials. Use cooled materials as required. Do not apply to substrates with temperatures of 90 deg F (32 deg C) and above.

#### **1.10 INSTALLATION REQUIREMENTS**

- A. Apply all repair material within manufacturer's guidelines.

## **PART 2 – PRODUCTS**

### **2.01 MANUFACTURERS**

- A. Source Limitations: For repair products, obtain each color, grade, finish, type, and variety of product from single source and from single manufacturer with resources to provide products of consistent quality in appearance and physical properties.

### **2.02 BONDING AGENTS**

- A. Mortar Scrub Coat: Mix consisting of 1 part portland cement and 1 part fine aggregate complying with ASTM C 144 except 100 percent passing a No. 16 (1.18-mm) sieve.

### **2.03 PATCHING MORTAR – SPALLS**

- A. Patching Mortar Requirements:
  - 1. Only use patching mortars that are recommended by manufacturer for each applicable horizontal, vertical, or overhead use orientation.
  - 2. Coarse Aggregate for Patching Mortar: ASTM C 33/C 33M, washed aggregate, Size No. 8, Class 5S. Add to patching-mortar mix only as permitted by patching-mortar manufacturer.
- B. Cementitious Patching Mortar: Packaged, dry mix for repair of concrete.
  - 1. Approved material is Sika Repair VOH as manufactured by Sika Corp. or approved equal.

### **2.04 MISCELLANEOUS MATERIALS**

- A. Water: Potable.

### **2.05 MIXES**

- A. General: Mix products, in clean containers, according to manufacturer's written instructions.
  - 1. Do not add water, thinners, or additives unless recommended by manufacturer.
  - 2. When practical, use manufacturer's premeasured packages to ensure that materials are mixed in proper proportions. When premeasured packages are not used, measure ingredients using graduated measuring containers; do not estimate quantities or use shovel or trowel as unit of measure.
  - 3. Do not mix more materials than can be used within time limits recommended by manufacturer. Discard materials that have begun to set.
- B. Mortar Scrub Coat: Mix dry ingredients with enough water to provide consistency of thick cream.

## **PART 3 – EXECUTION**

### **3.01 CONCRETE MAINTENANCE**

- A. Comply with manufacturers' written instructions for surface preparation and product application.
- B. Spall repairs to be completed with patching mortar and/or new concrete placement as determined by the contractor.

### **3.02 EXAMINATION**

- A. Notify Engineer seven days in advance of dates when areas of deteriorated or delaminated concrete and deteriorated reinforcing bars will be located.
- B. Locate areas of deteriorated or delaminated concrete using hammer or chain-drag sounding and mark boundaries. Mark areas for removal by simplifying and squaring off boundaries. At columns and walls make boundaries level and plumb unless otherwise indicated.
- C. Perform surveys as the Work progresses to detect hazards resulting from concrete-maintenance work.

### **3.03 PREPARATION**

- A. Ensure that supervisory personnel are on-site and on duty when concrete maintenance work begins and during its progress.
- B. Protect persons, equipment and surrounding surfaces of the structure being repaired from harm resulting from concrete maintenance work.
  - 1. Comply with each product manufacturer's written instructions for protections and precautions. Protect against adverse effects of products and procedures on people and adjacent materials, components, and vegetation.
  - 2. Use only proven protection methods appropriate to each area and surface being protected.
  - 3. Contain dust and debris generated by concrete maintenance work and prevent it from reaching the public or adjacent surfaces.
- C. Preparation for Concrete Removal: Examine construction to be repaired to determine best methods to safely and effectively perform concrete maintenance work. Examine adjacent work to determine what protective measures will be necessary. Make explorations, probes, and inquiries as necessary to determine condition of construction to be removed in the course of repair.
  - 1. Inventory and record the condition of items to be removed for reinstallation or salvage.

### **3.04 CONCRETE REMOVAL - SPALLS**

- A. Saw-cut perimeter of areas indicated for removal to a depth of at least 1/2 inch (13 mm). Make cuts perpendicular to concrete surfaces and no deeper than cover on reinforcement.
- B. Remove deteriorated and delaminated concrete by breaking up and dislodging from reinforcement.
- C. Remove additional concrete if necessary to provide a depth of removal of at least 1/2 inch (13 mm) over entire removal area.
- D. Where half or more of the perimeter of reinforcing bar is exposed, bond between reinforcing bar and surrounding concrete is broken, or reinforcing bar is corroded, remove concrete from entire perimeter of bar and to provide at least 1 1/2 inch clearance around bar.
- E. Test areas where concrete has been removed by tapping with hammer, and remove additional concrete until unsound and disbonded concrete is completely removed.
- F. Provide surfaces with a fractured profile of at least 1/8 inch (3 mm) that are approximately perpendicular or parallel to original concrete surfaces. Restore original profile unless otherwise directed.
- G. Thoroughly clean removal areas of loose concrete, dust, and debris.
- H. Payment is a separate line item "Foundation Spall Repair" based on the quantity of 2 square feet at 2 inches deep, which the owner reserves the right to increase, decrease or delete.

### **3.05 BONDING AGENT APPLICATION – SPALL REPAIR**

- A. Mortar Scrub Coat for Job-Mixed Patching Mortar and Concrete: Dampen repair area and surrounding concrete 6 inches (150 mm) beyond repair area. Remove standing water and apply scrub coat with a brush, scrubbing it into surface and thoroughly coating repair area. If scrub coat dries, recoat before placing patching mortar or concrete.
- B. Slurry Coat for Cementitious Patching Mortar: Wet substrate thoroughly and then remove standing water. Scrub a slurry of neat patching mortar into substrate, filling pores and voids.

### **3.06 PATCHING MORTAR APPLICATION – SPALL REPAIR**

- A. Place patching mortar as specified in this article unless otherwise recommended in writing by manufacturer.
  - 1. Provide forms where necessary to confine patch to required shape.
  - 2. Wet substrate and forms thoroughly and then remove standing water.
- B. Pretreatment: Apply specified slurry coat.

- C. General Placement: Place patching mortar by troweling toward edges of patch to force intimate contact with edge surfaces. For large patches, fill edges first and then work toward center, always troweling toward edges of patch.
- D. Consolidation: After each lift is placed, consolidate material and screed surface.
- E. Multiple Lifts: Where multiple lifts are used, score surface of lifts to provide a rough surface for placing subsequent lifts. Allow each lift to reach final set before placing subsequent lifts.
- F. Finishing: Allow surfaces of lifts that are to remain exposed to become firm and then finish to a surface matching adjacent concrete.



## **SECTION 05 00 00** **METAL REPAIRS**

### **PART 1 - GENERAL**

#### **1.01 SECTION INCLUDES**

- A. Steel and Miscellaneous Repairs.
- B. Surface Preparation of Heavy Metal Paint before Welding.

#### **1.02 REFERENCES**

- A. AWWA D100 Weld Standard
- B. AWS Weld Standard
- C. API 650 Standard

#### **1.03 OMISSIONS**

- A. The specifications include all work and materials necessary for completion of the work. Any incidental item(s) of material, labor, or detail(s) required for the proper execution and completion of the work are included.

#### **1.04 DEFINITIONS**

- A. Ground Flush: Ground even with adjacent metal with no transition. This preparation is intended for all removed items.
- B. Ground Smooth: Ground welds to the point that no cuts or scratches occur when rubbing your hand over the weld. Rebuild with weld any concavity discovered during grinding. This preparation is intended for all newly added steel.

#### **1.05 WORK INCLUDED**

- 1) Replace the riser manway gaskets.
- 2) Install a gasket on the wet interior roof hatch.
- 3) Install a hasp on the wet interior roof hatch.
- 4) Install handholds at the wet interior roof hatch.
- 5) Overflow discharge modification.
- 6) Adjust fall prevention device on the dry interior access tube and wet interior ladders.
- 7) Install bowl rigging couplings.
- 8) Install painter's railing stand-offs.
- 9) Patch plate on the wet interior platform
- 10) Weld a plate around the overflow penetration at the bottom of the access tube.
- 11) Access leg drain holes.

## **1.06 WORKMANSHIP**

- A. Provide material and workmanship necessary to produce a first-class job.
- B. All weld spatter is to be removed prior to coating application.
- C. All removed steel items are to be ground flush with surrounding surface. All new welds are to be ground smooth.
- D. The Contractor is to properly dispose of all removed items.

## **1.07 WELDER QUALIFICATIONS**

- A. Certified for type and position of weld specified.
- B. The welder shall be specialized in industrial or heavy commercial welding and experienced in rigging and elevated work.

## **1.08 SUBMITTALS**

- A. Safety Data Sheets (SDS) – for all items as required by law.
- B. Welder’s certification.
- C. Submit materials at least one (1) week prior to preconstruction meeting.

## **1.09 WORK SEQUENCING**

- A. The following is NOT a ways-and-means decision of the Contractor. It is accepted and good painting practice and shall be completed by the Contractor in this specified fashion:
  - 1. Complete ahead of all cutting and welding all surface preparation, such as removal of heavy metal bearing coating in the immediate area.
  - 2. Complete all welding repairs prior to commencement of any power washing or abrasive blast cleaning.
  - 3. Remove existing items that are not to be painted after water cleaning, store in a secure location.
  - 4. Disassemble appurtenances with mating surfaces (i.e. overflow flap gate, vent flange, etc.), surface prepare and coat mating surfaces and reassemble after topcoat is dry.
  - 5. Remove fall prevention devices in areas to be coated before painting, and reinstall after completion. Supply temporary fall prevention devices with steel cables during blasting and painting.

## **1.10 NEW STEEL COATING**

- A. The new carbon steel and weld burn surfaces are to be prepared and coated in accordance with Sections 09 97 13 and 09 97 13.10.

## **PART 2 – PRODUCTS**

### **2.01 STEEL PLATING and OTHER STRUCTURAL SHAPES**

- A. General Steel: ASTM – A36.
- B. General Stainless Steel: ASTM – 316.
- C. Threading on all couplings and plugs to meet NPT standards.

### **2.02 BOLTS and NUTS**

- A. Stainless Steel
  - 1. ASTM F594G – 316 Stainless Steel Bolts.
  - 2. ASTM F594G – 316 Stainless Steel Nuts.
- B. Galvanized Steel
  - 1. ASTM A307 Grade A zinc coated Steel Bolts.
  - 2. ASTM A307 Grade A zinc coated Nuts.

### **2.03 WELDS**

- A. Final – E70XX Electrodes.
- B. Root – E60XX Electrodes.
- C. Wire – ER70S Electrodes.

### **2.04 OVERFLOW SCREEN**

- A. 316 stainless steel wire, twenty-four (24) mesh or smaller.
- B. Manufactured/supplied by McMaster-Carr. [www.mcmaster.com](http://www.mcmaster.com) (562) 692-5911, manufactured by McNichols [www.mcnichols.com](http://www.mcnichols.com) (877) 219-6821, or approved equal.

## **PART 3 - EXECUTION**

### **3.01 MANWAY GASKETS**

- A. Replace the two riser manway gaskets with new  $\frac{3}{8}$  in. flat neoprene gasket material.
- B. Gaskets to meet ASTM D2000-86E, Type BC with a 70A durometer rating.
- C. Payment is incidental to the project.

### **3.02 ROOF HATCH GASKET**

- A. Install a gasket on the wet interior roof hatch cover.
- B. Gasket to be  $\frac{1}{4}$  inch EPDM or neoprene.
- C. Install after the exterior coating is dry to the touch.
- D. Apply gasket using adhesive, 3M Super Weatherstrip and Gasket Adhesive or approved equal.

- E. The hatch hasps may need to be modified/holes in the hasps enlarged to accept a lock once the gasket is installed.
- F. Payment is incidental to the project.

### **3.03 ROOF HATCH HASP**

- A. Install a hasp on the wet interior roof hatch so a padlock can be installed.
- B. Remove the existing hasp. Grind the old welds flush and reweld the hasp using ¼ inch full fillet welds.
- C. See Drawing 01.
- D. Payment is a separate line item “Roof Hatch Hasp” which the Owner reserves the right to delete.

### **3.04 HANDHOLD**

- A. Furnish and install a handhold on the wet interior roof hatch.
- B. Handhold to be a ¾ in. diameter rod shaped into a 16 in. x 3 in. “U”. Weld using a ¼-in. full fillet.
- C. The handhold is to be located on the ladder side of the opening.
- D. Payment is incidental to the project.

### **3.05 OVERFLOW DISCHARGE MODIFICATION WITH ELBOW AND FLAP GATE**

- A. Trim the end of the overflow and install a downward facing elbow. Install a flap gate on the new elbow.
- B. The flap gate shall allow for closed positioning during non-flow conditions, and open operation during overflow conditions.
- C. Field verify existing overflow pipe dimensions.
- D. Use steel plates as weights attached to the lever arm to assure complete closure at end of cycle, number may need to be more than shown on the drawing to ensure complete closure.
- E. Install PVC or plastic washers and/or spacers between the hinge bolts and lever arm, use enough washers to ensure a snug fit without damaging the coating during movement.
- F. Weld a flange onto the discharge end of the overflow pipe. Use a minimum of ¼” steel plate, flange outside diameter to match that of the flap gate outside diameter.
- G. See Drawing 02a-02b.
- H. Payment is a separate line item “Overflow Pipe Discharge Modification” which the Owner reserves the right to delete.

### **3.06 FALL PREVENTION DEVICE**

- A. Adjust the fall prevention devices on the dry interior access tube ladder and on the wet interior ladder.
- B. The fall prevention devices are to be aligned so they are in the center of each ladder.

C. Payment is incidental to the project.

### **3.07 BOWL RIGGING COUPLINGS**

- A. Install extra heavy couplings in the bowl.
- B. Couplings to be located at the mid-point between the riser and each leg. Locate in each bay, between the radial arms.
- C. Install four (4) additional couplings in the bowl within 24 in. of the riser.
- D. Install a steel plug at each coupling. Caulk the underside of the coupling. All threaded fittings to be coated with pipe joint compound.
- E. Engineer to field verify location of the couplings.
- F. See Drawing 03.
- G. Payment is incidental to the project.

### **3.08 PAINTER'S RAILING STAND-OFFS**

- A. Install a stand-off at the unsupported butt welds on the existing painter's railing.
- B. There are ten (10) unsupported butt welds, Contractor to field verify number of unsupported butt welds.
- C. See Drawing 04.
- D. Payment is a separate line item "Painter's Railing Stand-offs" which the Owner reserves the right to delete.

### **3.09 WET INTERIOR PLATFORM PATCH PLATE**

- A. Weld a patch plate over the opening in the wet interior platform.
- B. Weld ¼ in. plates over the opening using  $\frac{3}{16}$  in. continuous fillet weld on both sides.
- C. Plate to overlap the hole by a minimum of ½ in. on all sides.
- D. Payment is a separate line item "Wet Interior Platform Patch Plate" which the Owner reserves the right to delete.

### **3.10 OVERFLOW PIPE PATCH PLATES**

- E. Weld a plate at the gap around the overflow pipe penetration through the access tube.
- F. Weld a ¼ in. plate around the entire penetration. Weld using  $\frac{3}{16}$  in. continuous fillet weld on the exterior.
- G. Plate to overlap the hole by a minimum of ½ in. on all sides. The ends are to be welded using full penetration welds.
- H. Payment is a separate line item "Overflow Pipe Penetration Patch Plate" which the Owner reserves the right to delete.

### **3.11 LEG DRAINAGE HOLES**

- A. Drill ¾ in. drainage holes in the bottom of the access leg.
- B. Drill two holes spaced 180 degrees apart. Locate at the bottom of the leg.

- C. Remove all burs after drilling.
- D. Payment is incidental to the project.

#### **PART 4 – SPECIAL PROVISIONS**

##### **4.01 STEEL REPLACEMENT COATING**

- A. All large pieces of steel to be shop primed using the specified prime coat over a SSPC-SP10 near white surface preparation.
- B. Do not prime 3 in. from area to be welded.
- C. After installation, spot clean welded areas to a SSPC-SP11 and apply coating as specified.
- D. Use only one manufacturer for repair coating.
- E. Payment is incidental to metal repairs.

##### **4.02 WELD PREPARATION PRIOR to COATING**

- A. Prepare all new welds per NACE RPO 0178 prior to coating application. Grind welds to category D.

##### **4.03 SURFACE PREPARATION – PREWELDING – LEAD/CHROMIUM PAINT**

- A. The existing exterior and dry interior coating is known to contain lead and/or chromium.
- B. Remove all coating 6-in. on both sides of welding area by abrasive blast cleaning or vacuum shrouded power tool cleaning prior to any cutting or welding.
- C. Chemical stripping or other method may be approved by the Engineer.
- D. Do not begin any repair work until all adjacent coating is properly removed.

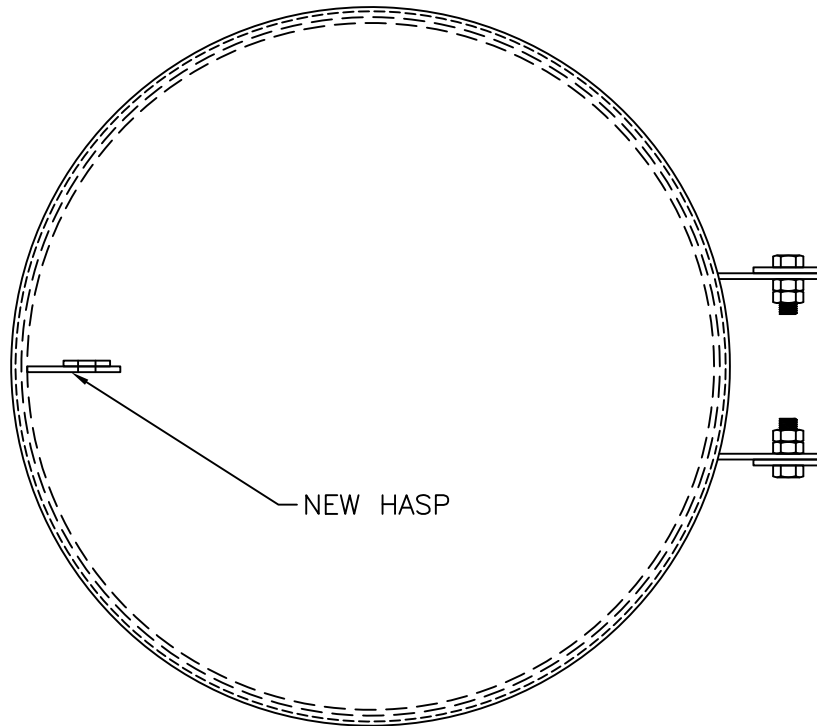

1/4" x 2" x 4"  
 HASP PLATE  
 ROUND-OFF  
 CORNERS

1/4" x 2" x 4"  
 HASP PLATE,  
 ROUND-OFF  
 CORNERS

MANWAY COVER

1/4"

1/4" TYP

DRILL 1"Ø HOLE THROUGH  
 COVER PLATE AND  
 1" X 2" OBLONG HOLE  
 IN ATTACHMENT PLATE

Note: Drawing not to scale.



Muskegon, MI 1,000,000 Roberts

Roof Hatch Hasp

Drawn By: TMF

Date: 02/08/22

Checked By: JVR

DWG: 01

INSTALL PIPE EXTENSION  
AS NEEDED SO THE  
DISCHARGE IS OVER THE  
EXISTING SPLASH PAD

EXISTING 6"Ø OVERFLOW PIPE,  
FIELD VERIFY SIZE

SCH 20  
ELBOW

TRIM THE PIPE  
PAST THE EXISTING  
ELBOW, INSTALL  
EXTENSION AS  
NEEDED SO THE  
DISCHARGE IS 12-24"  
ABOVE GRADE, SEE  
WELD DETAIL

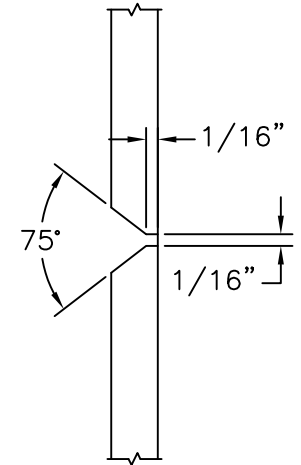

1/4"

SEE WELD  
DETAIL

SCH 20  
45° ELBOW

INSTALL OVERFLOW  
FLAP GATE  
PER DWG. 02b

12-24"

NEW 1/4" FLANGE

GROUND

WELD DETAIL

Note: Drawing not to scale.



Muskegon, MI 1,000,000 Roberts

Overflow Discharge

Drawn By: TMF | Date: 02/08/22

Checked By: JVR | DWG: 02a



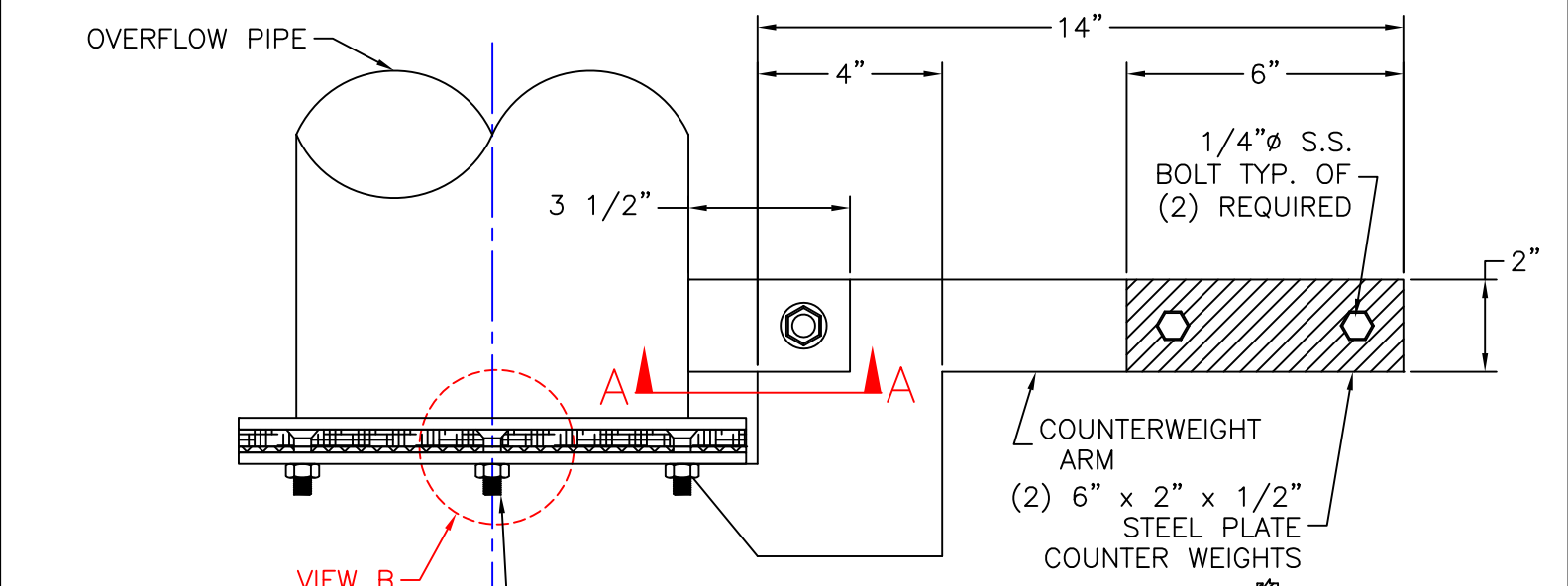

SECTION A-A



ISO VIEW

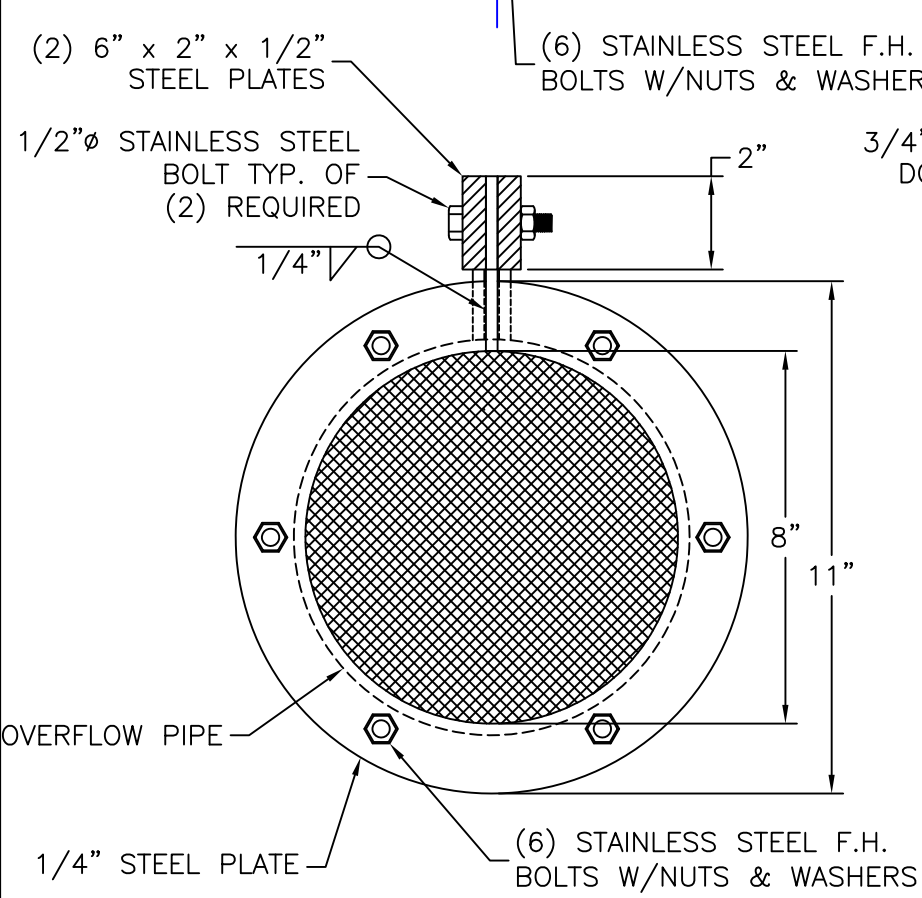

FLAP GATE

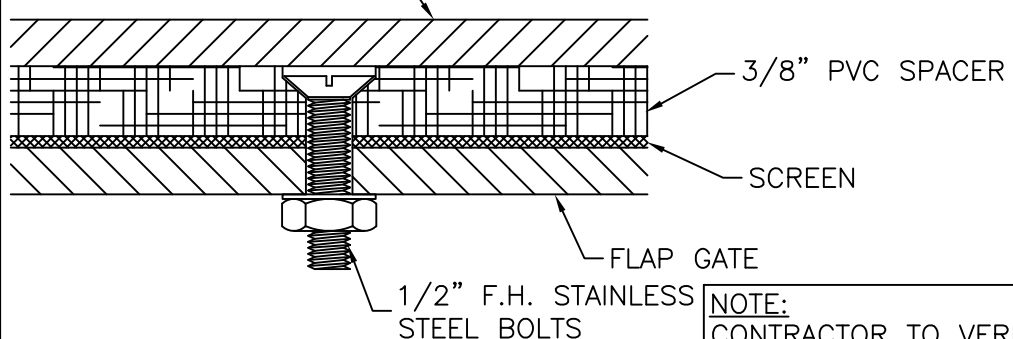

VIEW B

NOTE:  
CONTRACTOR TO VERIFY  
OVERFLOW PIPE SIZE IS  
8"  $\phi$  PRIOR TO CONSTRUCTION

Note: Drawing not to scale.

**DIXON**  
ENGINEERING, INC.

Muskegon, MI 1,000,000 Roberts

8" Overflow Flap Gate

Drawn By: TMF	Date: 02/08/22
Checked By: JVR	DWG: 02b

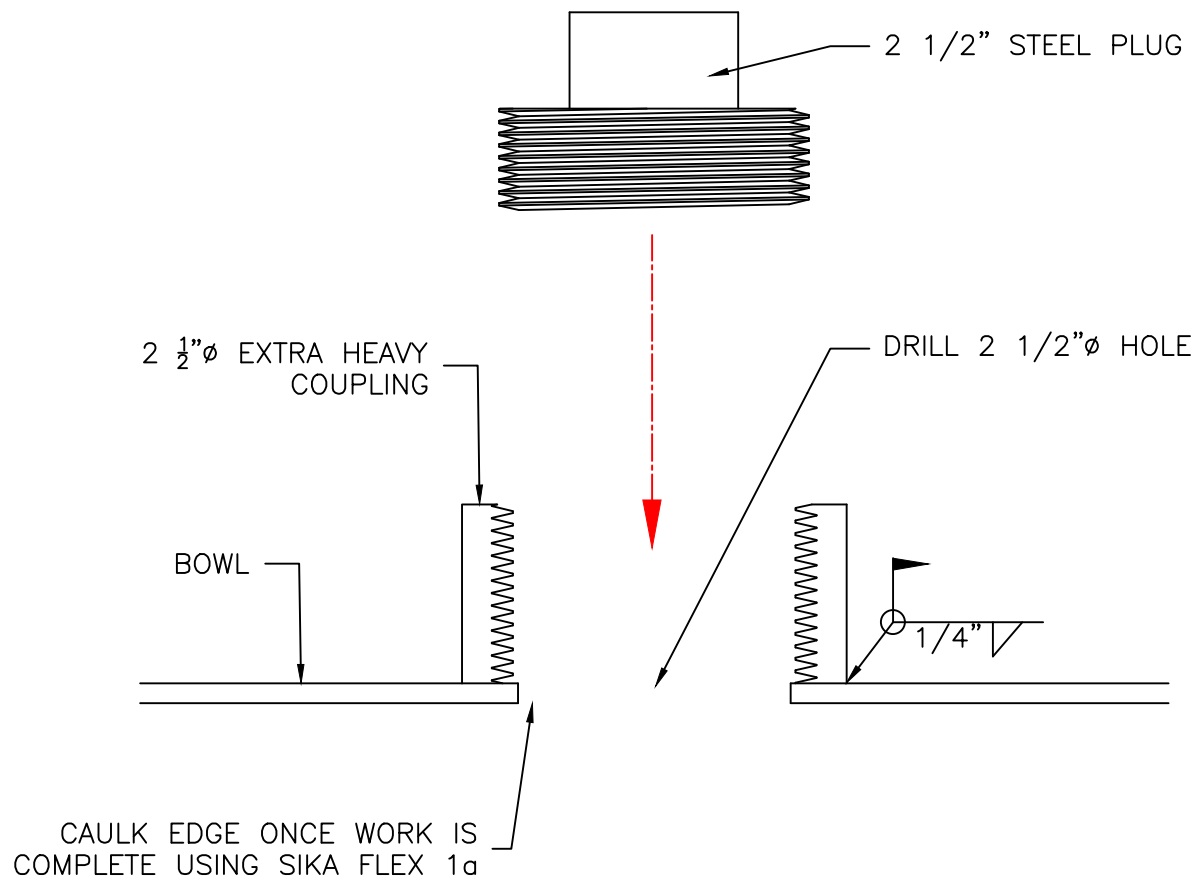

## BOWL RIGGING COUPLING

### NOTE:

1. INSTALL COUPLINGS UNDER THE BOWL. COUPLINGS TO BE DIRECTLY ON THE CENTER POINT BETWEEN THE RISER AND EACH LEG (OFFSET IN THE MIDDLE OF EACH BAY) WITH ONE COUPLING BETWEEN THE RISER AND EACH LEG.
2. INSTALL 4 COUPLINGS ON THE BOWL NEAR THE RISER EVENLY SPACED AND WITHIN 24" OF THE RISER.
3. THREADED CONNECTIONS ARE TO BE SEALED WITH PIPE JOINT COMPOUND (OATEY GREAT WHITE OR APPROVED EQUAL).
4. ENGINEER TO FIELD VERIFY LOCATION OF EACH COUPLING.

Note: Drawing not to scale.



Muskegon, MI 1,000,000 Roberts

Bowl Rigging Couplings

Drawn By: TMF Date: 02/08/22

Checked By: JVR DWG: 03

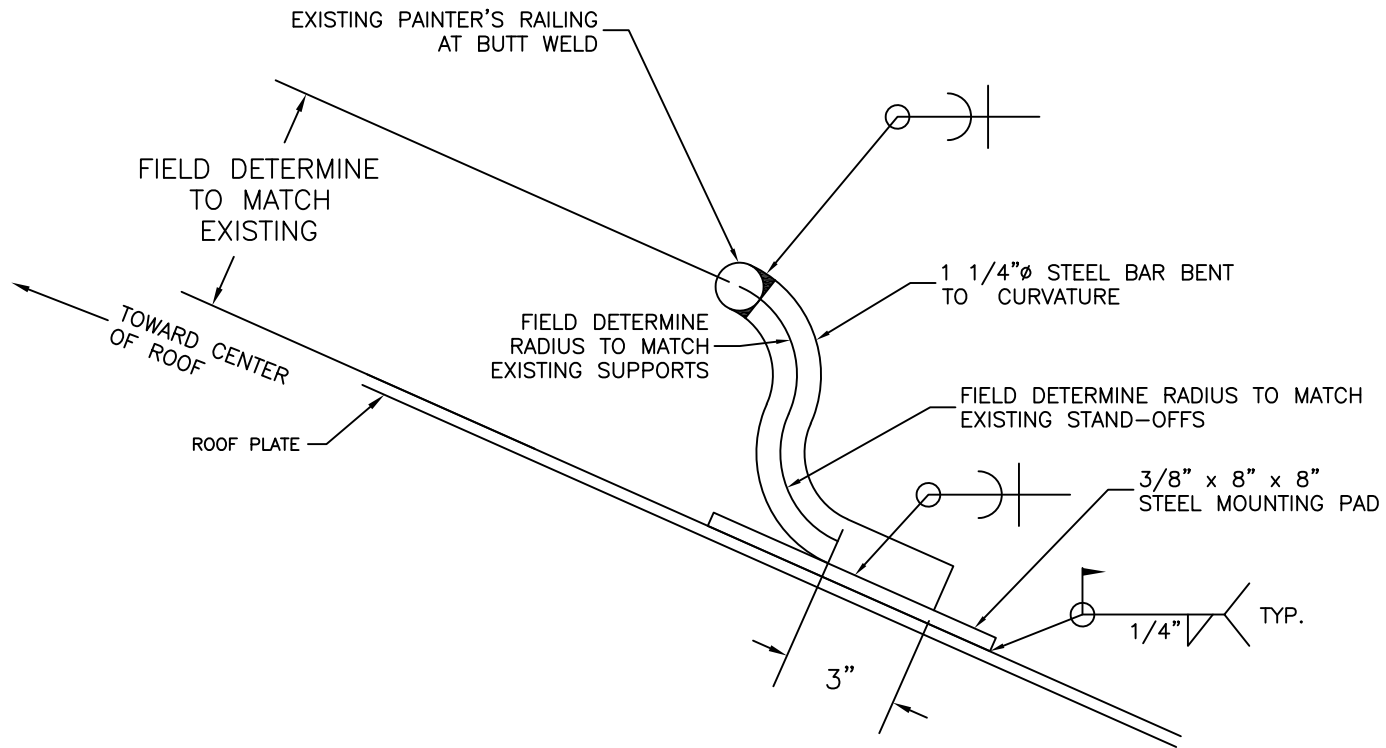

## PAINTER'S RAIL SUPPORT



ISO VIEW

Note: Drawing not to scale.

<b>DIXON</b> ENGINEERING, INC.	
Muskegon, MI 1,000,000 Roberts	
Painter's Railing Support	
Drawn By: TMF	Date: 02/08/22
Checked By: JVR	DWG: 04

## **SECTION 09 97 13** **STEEL COATING**

### **PART 1 – GENERAL**

#### **1.01 SECTION INCLUDES**

- A. Painting of steel structures.
- B. Interior cleaning and disinfection.

#### **1.02 REFERENCES**

- A. AWWA Standards:
  - 1. D102 – 17 Painting Steel Water Storage Tanks.
  - 2. C652 – Disinfection of Water Storage Facilities.
  - 3. C655 – Field Dechlorination.
- B. NSF/ANSI
  - 1. NSF/ANSI 600 and 600

#### **1.03 WORK INCLUDED**

- A. Exterior: Apply a three (3) coat epoxy urethane system.
- B. Wet Interior: Apply a spot two (2) coat epoxy system.
- C. Dry Interior: Apply a three (3) coat epoxy system.

#### **1.04 EXISTING CONDITIONS**

- A. Exterior: Acrylic system applied in 2003, known to contain heavy metals.
- B. Wet Interior: Epoxy system applied in 1991 with the roof coating applied in 2012.
- C. Dry Interior: Aluminum alkyd system known to contain heavy metals.

#### **1.05 OMISSIONS or INCIDENTAL ITEMS**

- A. It is the intent of these specifications to coat the structure for the purpose of corrosion protection on wet interior surfaces. It is the intent to coat the exterior for corrosion protection and aesthetics.
- B. Any small or incidental items not specifically detailed in the schedule, but obviously a part of the work are included in the work at no additional cost to the Owner.
- C. Engineer, as interpreter of the specifications, will determine if disputed items fall under this category. Prevailing custom and trade practices will be considered in this determination.

#### **1.06 SUBMITTALS**

- A. Submit the following with your annual prequalification:

1. Occupational Safety and Health Programs and certification that all site personnel have been trained as required by law.
- B. Submit the following ten (10) days prior to the preconstruction meeting:
  1. Safety Data Sheets (SDS) and Product Data Sheets:
    - a. Furnish from all suppliers Safety Data Sheets and product data sheets for all applicable materials including, but not limited to, paints, thinners, cleaners, degreasers, and abrasive materials.
    - b. Provide for employees one (1) copy of all data sheets at the job site for employee access.
    - c. Provide one (1) hard copy and an electronic copy to the Engineer.
    - d. No work may commence without the complete filing. All SDS shall conform to requirements of SARA (EPCRA) Right-to-Know Act.
  2. Ventilation Design Plan. Include airflow calculations, model numbers of the fans, and number of fans.
  3. Fall Prevention Plan and Site Specific Fall Hazard Evaluation:
    - a. Site specific plan to contain a generic drawing of the existing structure and appurtenances of this structure and reflect safety changes specified for this project.
    - b. Certifications for all spiders, scaffolding, stages, etc. to be used on the project. All certifications to be current, less than one year old.
- C. Submit the following at the preconstruction meeting:
  1. Designated OSHA Competent Person and qualifications, if not previously submitted.
- D. Submit the following within two (2) weeks of project completion with final pay request:
  1. Waste manifest, waste hauler and disposal facility. Required only if waste is hazardous.
  2. Waivers of lien.
  3. Copies of any formal worker safety or environmental citations received on the project.

#### **1.07 OWNER RESPONSIBILITY**

- A. Drain the structure with a seven (7) day notice after Contractor meets all precedent conditions of the contract.
- B. Fill the tank and draw samples and test after chlorination; responsibility of good results remains with the Contractor. Poor test results could result in added costs to Contractor, including re-chlorination, cost of water, plus possible liquidated damages.

## **1.08 DELIVERY and STORAGE of MATERIAL**

- A. Submit manufacturer's invoice, with or without paint cost, to the Engineer for review. This submittal will be used to identify the quantity of paint recommended by the manufacturer for a job of this size and design and will be used to check the quantity actually delivered to the project.
- B. Cover bulk materials subject to deterioration because of dampness, weather, or contamination, and protect while in storage.
- C. Maintain materials in original, sealed containers, unopened and with labels plainly indicating the manufacturer's name, brand, type, grade of material, and batch numbers.
- D. Remove from the work site containers that are broken, opened, water marked, and/or contain caked, lumpy, or otherwise damaged materials. They are unacceptable.
- E. Store the material in a climate controlled designated area where the temperature will not exceed the manufacturer's storage recommendations. Heat the storage area to the manufacturer's recommended minimum mixing temperature.
- F. Keep equipment stored outdoors from contact with the ground, away from areas subject to flooding, and covered with weatherproof plastic sheeting or tarpaulins.
- G. Store all painting materials in a location outside the structure.
- H. Do not store or have on-site unapproved material, material from different manufacturers, or materials from different projects.

## **1.09 ACCESS and RPR SAFETY**

- A. Provide access to all portions of the project where work is being completed. Access must be close enough and secure enough to allow RPR to use equipment without extensions.
- B. Provide personnel to assist with access and to ensure Contractor's access equipment is safely used.
- C. Provide separate fall protection devices and safety lines for the Owner and observers. Limit fall to 5 ft. vertically.
- D. New safety tie-off points have been added as part of this project, see Section 05 00 00 Metal Repairs. Do not rig equipment from these points. Provide separate fall protection cables and safety grabs for each tie-off point. The Contractor can install additional rigging couplings for staging. Coupling design for the additional couplings is to match those designed for safety lines.
  - 1. Tie-off points are located on the bowl for safety lines during exterior coating.
- E. These specifications require the Contractor to supply a separate fall protection cable and safety grab for each tie-off point for the observer's use. The Contractor is encouraged to provide a separate cable and tie-off for each worker. The cables may be connected to the same tie-off point as the RPR, but a separate cable and safety grab are required for each user.

### **1.10 OBSERVATION and TESTING**

- A. Prior to the scheduled observation, remove all dust, spent abrasive, and foreign material from the surface to be coated.
- B. The Contractor is to furnish an instrument for measuring the wet film thickness, and also a calibrated instrument for measuring dry film thickness of each field coat of paint. The dry film thickness testing gauge shall be the magnetic type as manufactured by Elcometer Co., or the Nordson Gauge Co.; spring loaded model with two percent (2%) accuracy margin over a range of one-to-twenty-one (1-100) mils or equal.
- C. The Engineer will furnish and operate observation equipment for their own use as quality assurance.
- D. Certify to the Owner that the specified paint has been applied at the paint manufacturer's recommended coverage, and to the specified thickness required. Also, certify that the paint has been applied in accordance with this contract.
- E. Take all necessary steps, including dry striping by brush or roller, to ensure a holiday-free coating system.
- F. The wet interior coating repairs are subject to low or high voltage holiday testing.
- G. The Owner and Engineer reserve the right to perform destructive testing under conditions deemed necessary. Testing may include, but is not limited to, the Tooke thickness test and adhesion testing. Any damage caused by these tests will be corrected to specifications at the Contractor's expense.

### **1.11 CLIMATIC CONDITIONS**

- A. Do not apply paint when the temperature, as measured in the shade, is below the manufacturer's required ambient and surface temperatures.
- B. Do not apply paint to wet or damp surfaces, or during rain, snow, or fog.
- C. Do not apply paint when it is expected the relative humidity will exceed 85%, or the surface temperature is less than 5° above dew point, or the air temperature will drop below the manufacturer's requirements for proper cure. Anticipate dew or moisture condensation, and if such conditions are prevalent, delay painting until the observer is satisfied the surfaces are dry.

### **1.12 APPLICATION**

- A. Complete all painting and surface preparation in strict accordance with these specifications, approved paint manufacturer's specifications, and good painting practices per SSPC.
- B. Apply each coating at the rate and in the manner specified by the manufacturer. Check the wet film thickness every 200 sq. ft. to ensure each coat applied meets the dry film thickness range requirements.

- C. Allow sufficient time for each coat of paint to dry and cure. Allow a minimum of twenty-four (24) hours between coats, unless product requirements have a maximum time less than 24 hours.
- D. Apply exterior coating by brush and roller only. Spray application is not permitted without prior approval of the Engineer. Even with prior approval, responsibility for damage still remains with the Contractor.
- E. Coatings shall be applied using methods to eliminate roller or spray marks in the finished product on the exterior.
- F. Painting may be delayed because of poor coverage or the potential damage from overspray and/or dry spray. In all cases, responsibility for damages rests with the Contractor.
- G. The Contractor is responsible for the appearance of the finished project and is warned to prevent contact with any freshly applied coating. Removal of rigging shall be completed so not to mar or damage the coating.
- H. Stripe the wet interior prior to the application of the final coat.
- I. Stripe the dry interior platforms at the outer edge, the access tube, and the bowl/transition cone, in the dry interior prior to application of final coat.
- J. Additional coats required for coverage or to eliminate roller marks, spray marks and to repair dry spray and overspray are the responsibility of the Contractor at no additional cost to the Owner.
- K. Use of pole extension on spray guns is prohibited for all paint application.
- L. Mixing of partial kits is not permitted. All partial cans of coating must be removed from the site.
- M. Mixing blades to be clean. The Engineer has the right to reject mixing blades based on cleanliness or paint build-up. Do not use the same mixing blade for different coatings (i.e. epoxy and urethane coatings).

### **1.13 PRESSURE RELIEF VALVES**

- A. Furnish two (2) pressure relief valves.
- B. The valves shall be Aquatrol series 69F1 or approved equal.
- C. Valves will need to be fitted with hydrant thread adaptor. Valves to be adjustable with range a minimum of 30 to 90 psi. Set valve at 60 psi.
- D. Supply three (3) days prior to draining of the structure.
- E. After work to the structure and successful disinfection have been completed, the Owner will return the valves to the possession of the Contractor.
- F. Cost shall be incidental to project cost.



## **PART 2 – PRODUCTS**

### **2.01 COLOR**

#### **A. Exterior Coatings:**

1. Supply the Engineer with a color chart to allow the Owner ample time for the exterior topcoat color selection.
2. Factory tint the intermediate coat(s) for all areas of the structure if similar to the finish coat. Tinting shall be sufficient to allow visibility of the dissimilar color from 1 ft., and from 100 ft.
3. The Owner shall select or verify the topcoat color at the preconstruction meeting.
  - a. All bids shall be based on “white” color.

#### **B. Wet Interior and Dry Interior Coatings:**

1. The color is to be a different tint between coats. Tinting to be performed in the factory. The final color is to be white. The topcoat color is to be verified at the preconstruction meeting.

### **2.02 SUBSTITUTIONS**

- A. All coatings specified and approved herein have met or exceeded a specified list of ASTM standards. The materials specified are the standard to which all others shall be compared.
- B. The purpose is to establish a standard of design and quality, and not to limit competition.
- C. Manufacturers wishing to have their products approved are to have their coatings tested using the same test methods.
- D. Approval by ANSI/NSF Standard 61 is also a requirement for potable water contact coatings.
- E. The selection of coatings also has taken into consideration the manufacturer’s current and past performance on availability, stocking, and shipping capabilities, ability to resolve disputes, and any applicable warranties.

### **2.03 DUST COLLECTORS – AIR FILTRATION UNITS**

- A. Furnish and use a dust collector during all blasting work.
- B. Units to be equal in filtration capacity to Eagle Industries dust collectors. Other units may be used, but their substitution will be evaluated on efficiency at 0.5 micron size and airflow movement.
- C. Use 30,000 CFM minimum for wet interior work.
- D. Substitution of steel grit blasting may decrease the requirements above. New requirements will be defined by the Engineer based on the efficiency of the Contractor’s equipment.
- E. Furnish HEPA filters for dust collection.

- F. Number of dust collectors shall be sufficient to supply a 50 ft./minute downward draft at most areas. An average may be considered. Determination of actual containment plan will be the deciding factor. Calculations of airflow shall be included in the containment submittal.
- G. Use only new filters or filters certified clean.

#### **2.04 GROUND TARPS**

- A. Use impermeable ground tarps, 20 mils thick.
- B. Use ground tarps able to withstand the anticipated construction traffic without tearing or separating.

#### **2.05 EQUIPMENT COVERING**

- A. Use material that is 8 – 10 mils thick, and 100% impermeable to all vulnerable equipment.
- B. Use material resistant to tear and/or rip by mechanical action from abrasive blasting during blasting operations.
- C. Make coverings airtight by use of duct tape at the openings, or other suitable measures.
- D. Meet with representative of equipment Owner to verify covering will not damage equipment. Damage is the Contractor's responsibility. This includes not only the Owner's equipment, but also telecommunication antennas, cables, buildings, controls, etc.

#### **2.06 AIR DRYER for COMPRESSOR**

- A. Use air dryers sufficient to remove 98% of the moisture from the compressed air. Size the dryers on total cfm using manufacturer supplied charts. Upon request, supply charts to Engineer for verification.
- B. If the dryer fan is not operable, cease all blasting until the dryer is replaced or repaired.
- C. Supply air dryer with an air draw-off valve to check air for dryness, oil contamination, and cleanliness on the outlet side of the air dryer.
- D. For cleaning operations, draw clean air from the outlet side of the air dryer.

### **PART 3 – EXECUTION**

#### **3.01 DISINFECTION**

- A. Disinfect the completely painted structure in accordance with AWWA Standard C652 Chlorination Method No. 3.
- B. Furnish the material and labor necessary to disinfect the structure in the required manner. Any chlorine products used are to be NSF 60 approved. Assist the Owner

- during filling and ensure that any manways are free of leaks after filling. Contractor is to adjust the manways and replace gaskets as needed to ensure there are no leaks.
- C. Do not allow water to enter the distribution system until satisfactory bacteriological test results are received.
  - D. Owner is responsible to collect two consecutive bacteriological samples, 24 hours apart, following disinfection. Satisfactory results are required before the tank can be returned to service.
  - E. Water drained to waste may not contain any substances in concentrations that can adversely affect the natural environment. No total residual chlorine may be measured in water discharged to surface water. It is recommended that the water be dechlorinated per AWWA C655F Field Dechlorination.
  - F. Pay all additional expenses if it is necessary to repeat the testing and disinfection procedure as a result of defective work.

### **3.02 PROTECTION of NON-WORK AREAS**

- A. Protect all non-blasted/painted surfaces prior to all abrasive blast cleaning/painting.
- B. Thoroughly cover the fill/drain pipe, overflow pipe, and all other openings. Do not permit abrasive or paint chips to enter into the piping or distribution system. Use watertight seals on the pipes.
- C. Protect and seal all controls and electrical components (even if they are not in the immediate work area) that are in danger from the project. Coordinate with the Owner so all controls are shut down and/or vented if necessary.

### **3.03 ANTENNA SYSTEM PROTECTION**

- A. There are 19 antennas mounted on the roof. The number of antennas listed are from the last known condition, the Contractor is to field verify number of antennas.
- B. There are cables routed from the ground up to the antennas with miscellaneous sensitive equipment mounted on the structure and control equipment/buildings located on the ground.
- C. Use material that is 100% impermeable to cover and protect all antennas, antenna cables, and antenna controls/buildings.
- D. Use material resistant to tear by mechanical action from abrasive blasting, power washing and coating application.
- E. Payment for damage to antennas, antenna cables, miscellaneous equipment and/or antenna controls/buildings is the responsibility of the Contractor.
- F. Contact the Owner of each set of antennas one (1) week prior to the beginning of construction. Name of antenna companies will be available at the preconstruction meeting.

- G. Antennas may remain in service during the project. The Contractor is responsible for their own RF safety. Contractor to provide a minimum of one RF monitor for employees on site for the duration of the project.

### **3.04 ANTENNA EQUIPMENT COATING**

- A. Antenna equipment is to be surface prepared and coated to match the exterior tank per these specifications including but not limited to: brackets and mounting poles.
- B. All previously coated items are to be coated per the exterior specifications. Any galvanized, stainless steel or other uncoated materials are to remain uncoated.
- C. Cost is incidental to the project.

### **3.05 DUST CONTAINMENT – INTERIOR**

- A. Do everything within the Contractor's power to minimize dust as a nuisance.
- B. No visible dust release is allowed from roof openings and other access openings.
- C. Seal or close all openings prior to blasting (see ventilation requirements). Connect the air filtration unit directly to a manhole extension.
- D. Design the manhole extension to allow access of hoses through a side exit that is sealable after hoses are in-place. Install the air filtration unit directly to the end of the extension.
- E. Seal of the side exit will be tested by holding a smoke agent 6 in. outside the seal with the air filtration unit operating. If smoke is drawn to the seal area, additional sealing will be necessary.
- F. The Contractor may reverse this operation by connecting the air filtration unit to the roof manhole and sealing around the hose. Also seal the roof vent. A sealed semi-rigid structure also may be used where employees have access through a side door. 90% of the air draw must be from the tank proper.

### **3.06 VENTILATION REQUIREMENTS**

- A. Supply mechanical ventilation sufficient to change air in the tank six (6) times each hour during blast and coating operations.
- B. In calculating air exchange, the dust collector air capacity can be considered a part of the air being changed up to 50% of ventilation requirements.
- C. Use the manways with fans to move the required air.
- D. Ventilate wet interior areas a minimum of seven (7) days after completion of painting, or longer until the wet interior coating has fully cured. Maintain ventilation at the rate of two (2) complete air changes per hour. The Owner reserves the right to perform a MEK Solvent Double Rub Test per ASTM D 4752 to verify the cure of the coating film prior to returning the tank to service.
- E. Cost of ventilation is incidental to the project.

- F. Additional ventilation openings may have to be installed by the Contractor. Submit size, details, and location(s) for approval by the Owner prior to cutting any opening. All costs associated with repairs by a certified welder are incidental.
- G. Connect the air filtration unit per the above Dust Containment – Interior section. All fans on the roof and sidewalls must blow in. If all openings are not needed for ventilation, seal them. Zero release to the atmosphere will be permitted.

### **3.07 HAND WASH FACILITY**

- A. Provide OSHA approved hand wash facility with running water. Hot water is not required.
- B. Stock facility with soap and towels and keep supply replenished.
- C. Test water and dispose of properly after job is completed.

### **3.08 GROUND COVER during WATER CLEANING**

- A. Protect the ground from contamination. Tarp at least 10 ft. from the structure's base.
- B. Lap all ground tarps a minimum of 2 ft.

### **3.09 LIGHTING of WORKSPACE**

- A. Provide durable lighting fixtures designed for the intended work environment for use during blasting, painting, and during all observations.
- B. Encase portable lamps in a non-conductive, shatterproof material. Use only heavily insulated cable with an abrasive resistant casing.
- C. Install all temporary electrical items in accordance with all local, state, and federal codes, including OSHA.
- D. Protect from paint overspray and damage from abrasive materials.
- E. Measure required illumination during surface preparation and coating application at the work surface. Supply 20 ft. candles minimum illumination during blasting and painting, and 30 ft. candles minimum prior to and during observation, per SSPC-Guide 12. Inspect the prepared surface at the higher illumination prior to calling for observation. All work must conform to specification requirements prior to the scheduled observation.
- F. Measure the illumination at the work surface in the plane of the work.

## **PART 4 – SPECIAL PROVISIONS**

### **4.01 SCHEDULING**

- A. Complete all welding and any other work that damages the coating before paint operations begin, including surface preparation. The exception is paint removal in the weld area.

- B. If Contractor wants a variance in this schedule, request the change and give reason in writing to the Owner. The project manager will reply with a written Field Order if change is approved. Engineer reserves the right to put further restrictions in Field Order. If Contractor objects to restrictions, he may revert to the original specifications.

#### **4.02 GRASS RESTORATION**

- A. The Contractor is to report any damaged ground at the construction site in writing prior to mobilization of equipment, otherwise all repairs to the damaged ground will be the responsibility of the Contractor.
- B. Refill all holes, ruts etc. with clean topsoil, and level area around the construction site to the original grade.
- C. Fill material to be clean soil, no gravel, rocks or construction debris is to be used as fill material without the Owner's consent.
- D. Bring soil to a friable condition by disking, harrowing, or otherwise loosening and mixing to a depth of 3 in. – 4 in. Thoroughly break all lumps and clods.
- E. Rake area to be seeded. Sow seed at a minimum rate of 220 lbs/acre. Use seed intended for the climate.
- F. Work to be completed to the Owner's satisfaction.
- G. Cost is incidental to the project.

#### **4.03 SHRUB REMOVAL**

- A. Remove the shrubs immediately next to the structure.
- B. Remove shrubs including roots at a minimum depth of 12 inches.
- C. Refill all holes, ruts etc. with clean topsoil, and level area around the construction site to the original grade.
- D. Fill material to be clean soil, no gravel, rocks or construction debris is to be used as fill material without the Owner's consent.
- E. Bring soil to a friable condition by disking, harrowing, or otherwise loosening and mixing to a depth of 3 in. – 4 in. Thoroughly break all lumps and clods.
- F. Rake area to be seeded. Sow seed at a minimum rate of 220 lbs/acre. Use seed intended for the climate.
- G. Work to be completed to the Owner's satisfaction.
- H. Cost is incidental to the project.

## **SECTION 09 97 13.10**

### **STEEL COATING SURFACE PREPARATION**

#### **PART 1 – GENERAL**

##### **1.01 SECTION INCLUDES**

- A. Spot/Full Field Abrasive Blast Cleaning.
- B. Power Tool Cleaning.
- C. High Pressure Water Cleaning.

##### **1.02 REFERENCES**

- A. AWWA Standards:
  - 1. D102-17 Painting Steel Water Storage Tanks.
- B. SSPC and NACE Standards:
  - 1. SP11 – Power Tool Cleaning to Bare Metal.
  - 2. SP6/NACE No. 3 – Commercial Blast Cleaning.
  - 3. SP10/NACE No. 2 – Near-White Metal Blast Cleaning.
  - 4. SP12/NACE No. 5 – Surface Preparation and Cleaning of Metals by Waterjetting Prior to Recoating
  - 5. VIS 1 (Visual standard for abrasive blasted metal).
  - 6. VIS 3 (Visual standard for hand and power tool cleaned metal).

##### **1.03 WORK INCLUDED – SURFACE PREPARATION**

- D. Exterior: High pressure water clean (5,000 to 10,000 psi), spot power tool clean to a SSPC-SP11 standard.
- E. Wet Interior: Spot abrasive blast clean the coating failures to a SSPC-SP10 near-white metal standard.
- F. Dry Interior: Abrasive blast clean the entire access leg interior and access tube interior to a SSPC-SP6 commercial standard.
- G. Lead/Chromium Paint: For additional requirements see Section 09 97 13.12 Heavy Metal Coating Disposal.

##### **1.04 WASTE SAMPLING**

- A. Sample spent abrasive waste from the project. Keep waste from separate sections of the structure segregated. Send to a NLLAP certified lab and test for TCLP for eight (8) metals (Arsenic, Barium, Cadmium, Chromium, Lead, Mercury, Selenium and Silver).
- B. The Owner reserves the right to collect samples and to send them to their selected lab. This will be determined at the preconstruction meeting.
- C. Pay all lab fees for eight (8) metals TCLP analysis on spent abrasive waste samples.

## **PART 2 – PRODUCTS**

### **2.01 EXTERIOR CLEANER**

- A. United 727 Weather-Zyme as manufactured by United Laboratories, 320 37<sup>th</sup> Ave., St. Charles, IL 60174 1-800-323-2594.

### **2.02 ABRASIVE – COAL SLAG – PRETREATED and NON-LEAD SURFACES**

- A. The coal slag shall be 20-40 grade, or 30-60 grade.
- B. The abrasive shall be free of moisture, water soluble contaminants, dust, and oil.
- C. The abrasive shall be stored and covered to prevent moisture contamination.
- D. All leaking or spilling bags shall be removed, and affected areas properly cleaned.
- E. All slag abrasive shall meet the requirements of SSPC-AB1 “Mineral and Slag Abrasive” June 1, 1991-Grade 3.
- F. The use of silica sand, flint sand, and glass beads is prohibited.
- G. All abrasive and grit material used, and all equipment supplied shall be subject to approval of the Engineer. The abrasive or grit shall be sharp enough and hard enough to remove the mill scale, rust, and paint.

### **2.03 ABRASIVE with BLASTOX – EXTERIOR – DRY INTERIOR – LEAD BEARING COATINGS**

- A. The abrasive shall be 20-40 grade, or 30-60 grade coal slag blended with Blastox. The mixture shall be proportioned by supplier, but not less than 15% Blastox.
- B. Other low dust abrasive may be used at the same proportion.
- C. The abrasive shall be free of moisture, water soluble contaminants, dust, and oil.
- D. The abrasive shall be stored and covered to prevent moisture contamination.
- E. All leaking or spilling bags shall be removed, and affected areas properly cleaned.
- F. All slag abrasive shall meet requirements of SSPC-AB1 “Mineral and Slag Abrasive” June 1, 1991-Grade 3.
- G. The use of silica sand, flint sand, and glass beads is prohibited.
- H. All abrasive and grit material used, and all equipment supplied shall be subject to approval of the Engineer. The abrasive or grit shall be sharp enough and hard enough to remove the mill scale, rust, and paint.
- I. Blastox can be used for non-immersion surfaces only, this product is not approved for use inside potable water storage tanks.

### **2.04 RECYCLABLE STEEL GRIT – ALTERNATE**

- A. Use recyclable steel grit size G-25 or G-50.
- B. The abrasive is to be free of moisture, water soluble contaminants, dust, and oil.
- C. The abrasive is to be stored and covered to prevent moisture contamination.



- D. All leaking or spilling containers are to be removed, and affected areas properly cleaned.
- E. All recyclable steel grit shall meet requirements of SSPC-AB1 “Metallic Abrasive” June 1, 1991.
- F. All abrasive and grit material used, and all equipment supplied shall be subject to approval of the Engineer. The abrasive or grit shall be sharp enough and hard enough to remove the mill scale, rust, and paint.

### **PART 3 – EXECUTION**

#### **3.01 WET INTERIOR CLEANING**

- A. Low pressure water clean at 4,000 psi all surfaces and appurtenances to remove sediment, minerals, other contaminants, and any remaining water.
- B. Staining may remain in place, the Engineer to approve cleanliness.
- C. The cost is incidental to the project.

#### **3.02 HIGH PRESSURE WATER CLEANING - EXTERIOR**

- A. Solvent clean all visible grease, oil, salt, algae, and residue in accordance with SSPC-SP1.
- B. High pressure water clean all exterior surfaces and appurtenances at 5,000 – 10,000 psi to remove all dirt, chalk, algae, other foreign material, and all brittle or loose coating, rust, and mill scale. Operational pressure will be determined by the Engineer based on field conditions.
- C. Maintain a water jet nozzle distance of 2 in. – 10 in. away from the surface.
- D. Hold the water jet nozzle with 0° - 15° tip perpendicular (90°) to the surface at all times.
- E. Only use machines rated at and capable of achieving and maintaining 10,000 psi. Use of a rotating/reciprocating nozzle during water cleaning is permitted but not to increase the pressure of a washer rated lower than required.
- F. Do NOT exceed a rate of 10 sq. ft./minute.
- G. The gauge measuring time of use must be operational on the unit, if not operational the Contractor may be shut down and/or deducted price for rental of an operational unit from the final payment.
- H. Feather all edges using power tools per this specification.

#### **3.03 NEAR-WHITE METAL (SSPC-SP10) DRY BLAST – WET INTERIOR**

- A. Spot abrasive blast clean all surfaces including appurtenances where steel is exposed or rusted, or where coating is abraded as specified surfaces and appurtenances to a near-white metal finish (SSPC-SP10), latest edition thereof.
- B. Maintain a profile of 2.0 – 3.0 mils on abrasive blast cleaned surfaces.

- C. All interior abrasive blast cleaning is to be completed and all spent abrasive removed, and surfaces thoroughly cleaned prior to any primer application.
- D. Once an area is acceptable for painting, apply all coats and allow coating to cure to touch prior to resumption of blasting or blast the entire tank before painting, use dehumidification to hold the blast. It is the Contractor's discretion and responsibility to determine if the entire tank is to be blasted, or what size is to be blasted and coated (all coats).
- E. The Contractor is responsible for supplying heat and dehumidification to maintain blast conditions.

**3.04 COMMERCIAL BLAST (SSPC-SP6) – DRY INTERIOR**

- A. Abrasive blast clean all surfaces and appurtenances to a commercial finish (SSPC-SP6), latest edition thereof.
- B. Maintain a profile of 1.0 – 2.0 mils on abrasive blast cleaned surfaces.

**3.05 POWER TOOL CLEAN (SSPC-SP11) with VACUUM - EXTERIOR**

- A. Solvent clean all visible grease, oil, salts, and residue.
- B. Power tool clean all surfaces and appurtenances to bare metal (SSPC-SP11) in areas where steel is exposed or rusted, or where coating is abraded.
- C. Retain or produce a surface profile. Surface profile shall be greater than 1.0 mil.
- D. Feather all edges of adjacent coating with 3M Scotch-Brite Clean'n Strip discs a minimum of ½ in. from exposed steel.
- E. Attach a vacuum to all power tools. Size vacuum per manufacturer's recommendations for optimal recovery of spent paint debris. Attach a HEPA filter sized as required.
- F. Disposal of vacuumed waste is the responsibility of the Contractor. Follow instructions on waste containers and store as directed by the Owner.

**3.06 HAZARDOUS WASTE DISPOSAL**

- A. Contract directly with a licensed hazardous waste hauler who is properly licensed in the State of Michigan to haul hazardous material.
- B. Transport the debris for treatment to a licensed hazardous waste disposal site.
- C. The Contractor will not be paid any retainage until paperwork has been submitted, including submittal of the hazardous waste manifest. Any original of the hazardous waste manifest shall be returned to the Owner.
- D. Remove all hazardous waste from the site within thirty (30) days of completion of the blasting portion of the project.
- E. Payment for disposal of hazardous waste is incidental to the project.

### **3.07 WASTE DISPOSAL – NON-HAZARDOUS**

- A. If after testing of the spent abrasive material the TCLP tests indicate the abrasive is not a hazardous waste, dispose the abrasive in a waste disposal facility.
- B. All waste shall be handled by a licensed hauler. Supply the Owner with all proper documentation of the final disposal site. The actual bill of lading and all manifests will be required prior to any payment.
- C. Payment for non-hazardous waste disposal is incidental to interior or exterior painting.

### **3.08 WASTE DOCUMENTATION**

- A. Supply proper documentation of storage, transportation, and treatment, or disposal of the waste to the Owner. The Owner will retain sufficient funds from the Contractor to pay for hazardous waste transportation, treatment, and any possible fines until all documentation has been received. This retainage will be held, even if the waste has tested non-hazardous.

### **3.09 TESTING and CLEAN-UP of WASTE**

- A. Daily collect all spent abrasive from the ground tarps and dispose in the required receptacles. Prior to receiving test results, spent abrasive shall be stored on ground tarps. The spent abrasive is to be covered and weighted down so no dust can be released.
- B. Furnish containers with proper labels for storage of the spent debris. Containers shall meet requirements of the EPA (or their local counterpart) for hazardous waste disposal. The spent abrasive will be moved directly from the tank into the waste containers. The containers will remain until final test results have been received. Furnishing containers with covers will be incidental to respective repaint and will not be affected by the Owner's final selection of respective interior or exterior disposal.
- C. Waste to remain on-site in covered receptacles until waste test results are received.

## **SECTION 09 97 13.12**

### **HEAVY METAL BEARING PAINT REMOVAL and DISPOSAL**

#### **PART 1 – GENERAL**

##### **1.01 SECTION INCLUDES**

- A. Heavy Metal Bearing Paint Removal and Disposal.

##### **1.02 REFERENCES**

- A. SSPC Guide-7 Disposal of Lead Contaminated Surface Preparation Debris.

##### **1.03 PAINTER QUALIFICATIONS – HEAVY METAL BEARING PAINT PROJECTS**

- A. Contractor shall complete all coating and surface preparation.
- B. Painter shall be specialized in industrial or heavy commercial painting, and experienced in removing lead based coatings.
- C. ALL CONTRACTORS SHALL BE PREQUALIFIED WITH Dixon Engineering.
- D. Submit five (5) successful paint projects of similar nature with the bid proposal if the engineer is not familiar with the contractor's work.

##### **1.04 SUBMITTALS**

- A. Heavy Metal Coatings, Health & Safety Plan.
- B. Site Specific Plan including:
  - 1. Work procedures for each job classification.
  - 2. Administration and engineering controls to be used during exposure assessment period and expected exposure.
  - 3. Personal hygiene procedure.
  - 4. Site personnel register (updated as needed).
  - 5. Qualifications of competent persons and responsibilities. At this point, multiple qualified people may be submitted.
  - 6. 24 hour job site contact person.
  - 7. Site map showing ingress/egress and locate all equipment.

#### **PART 2 – PRODUCTS**

##### **2.01 ABRASIVE with BLASTOX – DRY INTERIOR**

- A. The abrasive shall be 20-40 grade, or 30-60 grade coal slag blended with Blastox. The mixture shall be proportioned by supplier, but not less than 15% Blastox.
- B. Other low dust abrasive may be used at the same proportion.
- C. The abrasive shall be free of moisture, water soluble contaminants, dust, and oil.
- D. The abrasive shall be stored and covered to prevent moisture contamination.

- E. All leaking or spilling bags shall be removed, and affected areas properly cleaned.
- F. All slag abrasive shall meet requirements of SSPC-AB1 Mineral and Slag Abrasive June 1, 1991-Grade 3.
- G. The use of silica sand, flint sand, and glass beads is prohibited.
- H. Blastox can be used for non-immersion surfaces only, this product is not approved for use inside potable water storage tanks.

## **2.02 RECYCLABLE STEEL GRIT – ALTERNATE**

- A. Use recyclable steel grit size G-25 or G-50.
- B. The abrasive is to be free of moisture, water soluble contaminants, dust, and oil.
- C. The abrasive is to be stored and covered to prevent moisture contamination.
- D. All leaking or spilling containers are to be removed, and affected areas properly cleaned.
- E. All recyclable steel grit shall meet requirements of SSPC-AB1 Metallic Abrasive June 1, 1991.

## **2.03 DECONTAMINATION FACILITY**

- A. Provide a climatic controlled decontamination facility. The decontamination facility must include a minimum of three separate areas: a dirty area, a showering area, and a clean area. The unit shall be as manufactured by Eagle Industries of Louisiana, Inc.
- B. Entry and exit into the showering room must be through an approved airlock designed to prevent cross-contamination between any two areas.
- C. Equip the clean room with adequately sized lockers for each worker to secure and store clothing, valuables, and other personal belongings.
- D. Equip the decon facility with an onboard ion exchange filtration system capable of filtering all wastewater generated during hand washing operations, showering, laundering of towels and clothing, or from any other water used in cleaning.
- E. Recordkeeping log signed by each employee upon exiting that time was provided and decon procedures were followed.

## **PART 3 – EXECUTION**

### **3.01 CLOTHING – CONTRACTOR**

- A. Provide protective clothing for all personnel – disposal or laundered is acceptable.

### **3.02 NOTIFICATION of NEIGHBORS**

- A. Enclose the entire project site, including the clean area, inside a yellow ribbon bearing the warning label of heavy metals.
- B. Post signs around the project stating “**CAUTION – HEAVY METAL HAZARD – DO NOT ENTER**”

- C. If the neighbors are in close proximity, the contractor shall participate in any education notification program originated by the owner.

**3.03 PERSONAL HYGIENE – HEAVY METAL BEARING PAINT PROJECTS**

- A. Register all personnel on the site and try to maintain, as much as possible, the same crew.
- B. Any changes in crew size or personnel will require registration. Registration simply means notification to the owner or engineer of a new person on the job site.
- C. Inform all personnel of the dangers involved with heavy metals from a health standpoint, and require use of washroom/decon facilities.
- D. Ensure proper use and compliance of personnel with health department and OSHA requirements.
- E. Complete contractor certification form that all employees complied with OSHA 1926.62 hygiene rules, and contractor, as employer, complied with their required OSHA housekeeping and compliance requirements.

**SECTION 09 97 13.14.01**

**WET INTERIOR STEEL COATING – REPAIR TWO COAT EPOXY**

**PART 1 – GENERAL**

**1.01 SECTION INCLUDES**

- A. Painting spot repairs in the wet interior.

**1.02 REFERENCES**

- A. SSPC and NACE Standards:
  - 1. PA1 – Paint Application.
  - 2. PA2 – Measurements and Calibration.
  - 3. NACE RP 0178 Surface Finish Requirements.

**1.03 WORK INCLUDED**

- A. Application of a two (2) coat repair epoxy system.

**PART 2 – PRODUCTS**

**2.01 EPOXY – 2 COAT REPAIR SYSTEM**

- A. System to meet all National Sanitation Foundation 61 certification standards for potable water contact.
- B. Approved suppliers and systems:

<u>Manufacturer</u>	<u>System</u>
Tnemec	L140 (spot)/L140(spot)
Induron	PE-70(spot)/PE-70(spot)
Sherwin Williams	Macropoxy 5500LT(spot)/Macropoxy5500LT(spot)

**PART 3 – EXECUTION**

**3.01 EPOXY – 2 COAT REPAIR SYSTEM**

- A. Apply a two (2) coat epoxy paint system to all prepared surfaces and appurtenances.
- B. Surface preparation has been previously defined in Section 09 97 13.10.
- C. Apply each coat at the following rates:

<u>Coat</u>	<u>Minimum</u>	<u>Maximum</u>
	<u>D.F.T. (mils)</u>	<u>D.F.T. (mils)</u>
Primer (spot)	3.5	4.5
Topcoat (spot)	<u>3.5</u>	<u>4.5</u>
Total	7.0	9.0

- D. Each full coat to be a different color from the previous coat and is to be approved by the engineer. No color bleedthrough should occur if proper application rates are observed.
- E. Apply all coats in uniform color and sheen without streaks, laps, runs, sags, cloudy, or missed areas. Correct all defects before application of the successive coat.
- F. Allow a minimum of twenty-four (24) hours between coats (including stripe coat). Additional time may be necessary if low temperatures require an increase in the necessary cure time.
- G. MAINTAIN FORCED VENTILATION A MINIMUM OF SEVEN (7) DAYS AFTER TOPCOAT APPLICATION, time required for cure is dependent on the coating manufacturer and temperature. Record variations of the standard procedures (roof hatch closure because of rain, etc.), and submit to the engineer. Heat is required if, in the opinion of the engineer, the integrity of the coating is endangered by cold weather, or if additional cure time will delay the project beyond the substantial completion date.

### **3.02 SCHEDULE of WORK**

- A. Complete all exterior and interior welding prior to surface preparation.



**SECTION 09 97 13.18.01**  
**DRY INTERIOR STEEL COATING – EPOXY SYSTEM**

**PART 1 – GENERAL**

**1.01 SECTION INCLUDES**

A. Painting in the dry interior.

**1.02 REFERENCES**

A. SSPC and NACE Standards:

1. PA1 – Paint Application.
2. PA2 – Measurements and Calibration.
3. NACE RP 0178 Surface Finish Requirements.

**1.03 WORK INCLUDED**

A. Application of a three (3) coat epoxy system.

**PART 2 – PRODUCTS**

**2.01 EPOXY SYSTEM**

A. Three (3) coat epoxy system.

B. Approved suppliers and system: Access tube and access leg.

<u>Manufacturer</u>	<u>System</u>
Tnemec	66/66/66(stripe)/66
Induron	PE-70/PE-70/PE-70(stripe)/PE-70
Sherwin Williams	646PW/646PW/646PW (stripe)/646PW

**PART 3 – EXECUTION**

**3.01 EPOXY SYSTEM**

A. Apply to all prepared areas a three (3) coat epoxy system.

B. Surface preparation has been previously defined in Section 09 97 13.10.

C. The access tube and access leg is to receive a three (3) coat system as follows:

<u>Coat</u>	<u>Minimum</u>	<u>Maximum</u>
	<u>D.F.T. (mils)</u>	<u>D.F.T. (mils)</u>
Primer	3.5	5.5
Intermediate	3.5	5.5
Stripe	1.5	2.5
Topcoat	<u>3.5</u>	<u>5.5</u>
Total	10.5*	16.5*

\*Stripe coat is not included in totals.

\*Stripe coat to be applied to all welds, angles, and sharp edges throughout the structure.

D. Each full coat to be a different color from the previous coat and is to be approved by the engineer. No color bleedthrough should occur if proper application rates are observed.

E. Apply all coats in uniform color and sheen without streaks, laps, runs, sags, cloudy, or missed areas. Correct all defects before application of the successive coat.

F. Allow a minimum of twenty-four (24) hours between coats (including stripe coat). Additional time may be necessary if low temperatures require an increase in the necessary cure time.

### **3.02 SCHEDULE of WORK**

A. Complete all exterior and interior welding prior to surface preparation.

**SECTION 09 97 13.24.08**

**EXTERIOR STEEL COATING – THREE COAT URETHANE OVERCOAT**

**PART 1 – GENERAL**

**1.01 SECTION INCLUDES**

- A. Painting on the exterior.

**1.02 REFERENCES**

- A. SSPC and NACE Standards:
  - 1. PA1 – Paint Application.
  - 2. NACE RP 0178 Surface Finish Requirements.

**1.03 WORK INCLUDED**

- A. Application of a three (3) coat urethane system.
- B. Application of lettering.

**PART 2 – PRODUCTS**

**2.01 URETHANE – 3 COAT OVERCOAT SYSTEM**

- A. The coating shall be a urethane system.
- B. The contractor is advised to follow all requirements for safety concerning isocyanates.
- C. Ultraviolet protection additives mixed at factory only. There will be no tinting or addition of any material other than the manufacturer’s thinners.
- D. Approved suppliers and systems:

<u>Manufacturer</u>	<u>System</u>
Tnemec	3600(spot)/3600/1095/1094
Induron	Ebond100(spot)/Ebond100/ I-6600/I-6600
Sherwin Williams	920/920/Acrolon Ultra/Acrolon Ultra

**PART 3 – EXECUTION**

**3.01 URETHANE – 3 COAT OVERCOAT SYSTEM**

- A. Apply to all prepared surfaces and appurtenances a three (3) coat urethane system.
- B. Surface preparation and paint requirements have been previously defined in Section 09 97 13.10. Only the spot prime and full prime coat of the mastic can be applied with spray equipment. The urethane coatings must be applied using a brush and roller.
- C. Apply each coat at the following rates:

<u>Coat</u>	<u>Minimum</u>	<u>Maximum</u>
	<u>D.F.T. (mils)</u>	<u>D.F.T. (mils)</u>
Primer (spot)	1.0	2.0
Intermediate	1.0	2.0
Urethane Intermediate	2.0	3.0
Topcoat	<u>2.0</u>	<u>3.0</u>
Total	6.0	10.0

- D. Each full coat to be a different color from the previous coat and is to be approved by the engineer. No color bleedthrough should occur if proper application rates are observed.
- E. Apply all coats in uniform color and sheen without streaks, laps, runs, sags, cloudy, or missed areas. Correct all defects before application of the successive coat.
- F. Allow a minimum of twenty-four (24) hours between coats. Additional time may be necessary if low temperatures require an increase in the necessary cure time.

### **3.01 LETTERING**

- A. Paint the name “WATCH MUSKEGON” in two (2) locations on the tank.
- B. Paint the lettering per the attached guideline. Locations to match the existing but size will need to be determined with the Owner prior to application.
- C. Approved Fluorourethane coating system.

<u>Manufacturer</u>	<u>System</u>
Tnemec	700
Induron	Perma-Gloss
Sherwin Williams	Fluorokem HS
- D. Apply lettering coating at 2.0 to 3.0 mils.
- E. Payment is a separate line item “Lettering” which the Owner reserves the right to delete.

### **3.02 SCHEDULE of WORK**

- A. Complete all exterior and interior welding prior to surface preparation.

**WATCH MUSKEGON**<sup>TM</sup>

brand guide prepared by **revel** 

### Preferred Usage

Horizontal  
Full color type  
Dark blue background

Use this whenever possible.

The logo is displayed horizontally in a bold, sans-serif font. The word "WATCH" is in blue, "MUSKE" is in orange, and "GON" is in green. A small trademark symbol (TM) is located at the end of the word "GON".

**WATCH MUSKEGON™**

### Alternate Usage

Vertical  
Full color type  
Dark blue background

For use when you don't have  
available horizontal space.  
Vertical banners for example.

The logo is displayed vertically in a bold, sans-serif font. The word "WATCH" is in blue, "MUSK" is in orange, and "EGON" is in green. A small trademark symbol (TM) is located at the end of the word "EGON".

**WATCH  
MUSK  
EGON™**



Alternate colorways

- A. Full color
- B. Full color on black
- C. Full color on white
- D. Grayscale on black
- E. Grayscale on white

The full color option (A) is preferred, but there may be situations that call for alternate colorways. The Watch Muskegon™ logo should only be used against these color backgrounds.

When used against a transparent background, such as window sticker, option C should be used.



## Colors

The Watch Muskegon™ logo colors vary slightly according to the color mode and the background color it's placed on.

- A. Full color on dark blue
- B. Full color on black
- C. Full color on white
- D. Grayscale on black
- E. Grayscale on white/transparent

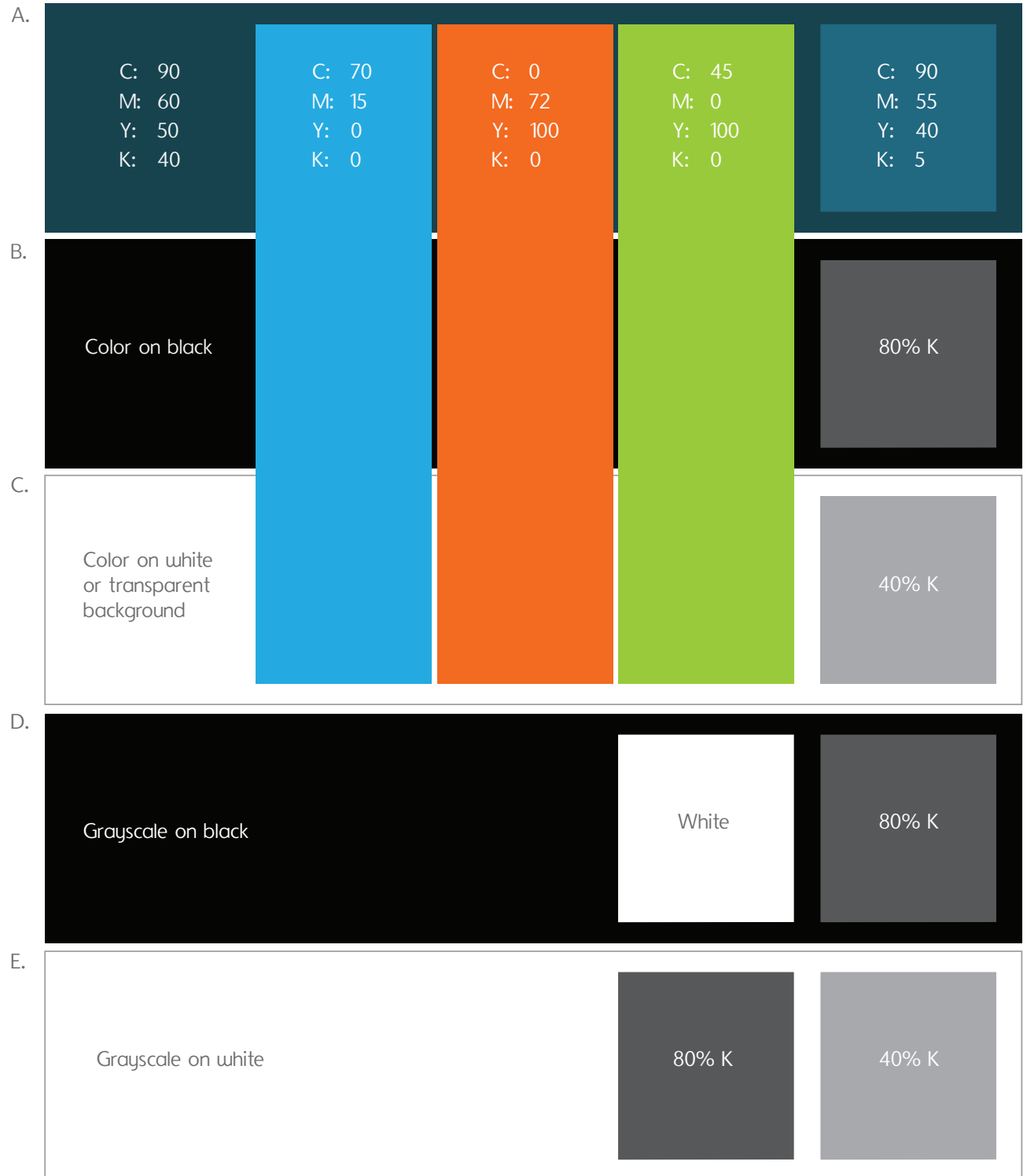



## No-No's

To maintain the integrity and consistency of the Watch Muskegon™ brand, please don't do these things.



Do not use against conflicting color backgrounds.



Do not alter the chosen color palette.



Do not distort the logo.



Do not use the words "Watch Muskegon" without highlighting the words "Watch..Us...Go."



Do not use alternate fonts.

## Fonts

When possible, the Gotham font family should be used to remain consistent in brand material. Gotham Ultra should be used for callout areas like headlines.

When Gotham is not available, acceptable substitutions include Arial and Helvetica.

### **Gotham Ultra**

**ABCDEFGHIJKLMNOPQRSTUVWXYZ  
abcdefghijklmnopqrstuvwxyz**

**0123456789**

### **Gotham Black**

**ABCDEFGHIJKLMNOPQRSTUVWXYZ  
abcdefghijklmnopqrstuvwxyz**

**0123456789**

### Gotham Book

ABCDEFGHIJKLMNOPQRSTUVWXYZ  
abcdefghijklmnopqrstuvwxyz

0123456789

**SECTION 09 97 23.23.01**

**CONCRETE FOUNDATION COATING – TWO COAT EPOXY**

**PART 1 – GENERAL**

**1.01 SECTION INCLUDES**

- A. Painting of the concrete foundations.

**1.02 REFERENCES**

- A. SSPC and NACE Standards:
  - 1. PA1 – Paint Application.
  - 2. PA2 – Measurements and Calibration.

**1.03 WORK INCLUDED**

- A. Application of a two (2) coat epoxy system.

**PART 2 – PRODUCTS**

**2.01 EPOXY – 2 COAT SYSTEM**

- A. Two (2) coat epoxy system.
- B. Approved suppliers and manufacturers:

<u>Manufacturer</u>	<u>System</u>
Tnemec	66/66
Induron	PE-70/PE-70
Sherwin Williams	646PW/646PW

**PART 3 – EXECUTION**

**3.01 EPOXY – 2 COAT EPOXY**

- A. Apply to all prepared areas a two (2) coat epoxy system.
- B. Remove dirt 3” below grade around the entire foundation prior to coating, backfill once topcoat is dry to the touch.
- C. Foundations to be water cleaned at 3,500 to 5,000 psi to remove all contaminants.
- D. Apply each coat at the following rates:

<u>Coat</u>	<u>Min. D.F.T. (mils)</u>	<u>Max. D.F.T. (mils)</u>
Primer	3.5	5.5
Topcoat	<u>3.5</u>	<u>5.5</u>
Total	7.0	11.0

- E. Allow the manufacturer’s minimum time between coatings.
- F. Cost is incidental to exterior painting.

**SECTION 13 32 12**  
**MIXING SYSTEM - GRIDBEE**

**PART 1 – GENERAL**

**1.01 EQUIPMENT OVERVIEW**

- A. These specifications provide the requirements to furnish, install, and place into operation a potable water storage tank mixer and associated equipment.

**1.02 REFERENCES**

- A. Occupational Safety and Health Administration, OSHA
- B. Department of Transportation, DOT
- C. Underwriters Laboratories Inc., UL 508
- D. NSF/ANSI Standard 61

**1.03 WORK INCLUDED**

- A. Install a complete mixing system including all wiring and attachments.
- B. Payment is a separate line item “Mixer” which the owner reserves the right to delete.

**1.04 QUALITY ASSURANCE**

- A. Continuous Operation Equipment. The circulation equipment shall operate continuously, all day and all night, using 120 VAC as the power source.
- B. No Visual Defects. The mixer shall have no visual defects, and shall have high quality welds, assembly, and corrosion resistant finish.
- C. Qualified US Manufacturer. The manufacturer of the equipment shall have extensive experience in the production of such equipment, and the equipment shall be manufactured in the continental United States.
- D. Warranty. The mixer shall be warranted to be free of defects in materials and workmanship for a period of 5 years. This equipment warranty would run directly from the manufacturer of the equipment to the owner. The equipment warranty would not be part of the contract or any required bond.

**1.05 SUBMITTALS**

- A. The awarded Bidder shall provide a digital copy and three (3) hard copies of the following documents. Upon acceptance of these documents by the Engineer, the Bidder will be issued a Notice to Proceed, and may then proceed to install the equipment.
  - 1. Manufacture Qualification Document
  - 2. List of Supplied Equipment
  - 3. Manufacturer Product Sheets

4. Electric Power Source Requirements
5. NSF/ANSI Standard 61 Documentation
6. Warranty Statement
7. Operation Manuals

**1.06 FIELD SERVICES**

- A. Installation personnel shall have received job-specific safety training which is to include: working over water, disinfecting procedures, confined space entry, and fall protection.

**PART 2 – PRODUCT SPECIFICATIONS**

**2.01 MANUFACTURER**

- A. Specified Equipment. The circulation equipment shall be manufactured by IXOM Watercare Inc. [www.ixomwatercare.com](http://www.ixomwatercare.com), (866) 437-8076 or be a pre-approved alternative.

**2.02 PERFORMANCE AND FEATURES**

- A. Complete Water Circulation Required. To meet the project objectives, the tank or reservoir circulation shall be achieved by a single or multiple submerged units within the reservoir capable of providing long distance circulation of water. The mixer shall have a direct measurable flow rate where suction shall enter specified mixer’s intake positioned within 2 inches of reservoir floor and discharging water vertically in a sheet flow pattern to induce a large volume, low velocity flow to reach the tank or reservoir water surface. The mixer must be placement flexible in design to allow best hydraulic positioning for tank or reservoir conditions to prevent hydraulic short circuiting within tank or reservoir. Suction not within 2 inches of tank or reservoir floor is not allowed.
- B. Unit required to meet the project objectives including number of machines required.

Quantity	Model	Tank or Reservoir
1	GridBee GS-12 120V	1,000,000 Gallon Radial Arm Tank with an estimated head range of 24 ft.

- C. Complete Mix: The mixer manufacturer guarantees that the subject tank will be completely mixed by the mixer. In continuous operation of the mixer:
- (1) at least once per 24 hours all water temperatures within the tank shall converge to within 0.8 degrees C, and

- (2) at least once per 72 hours all chlorine concentrations within the tank shall converge to within 0.18 mg/l.
- D. Fit Through Small Hatch Opening. The mixer shall be capable of fitting through a clear, unobstructed opening of 12" diameter without requiring disassembly or assembly.
- E. Continuous Operation With 120VAC, 20 Amp Power Source. The mixer shall operate continuously during day and night while connected to electric grid power.
- F. Stainless Steel Construction. The mixer shall be constructed primarily of Type 316 stainless steel metal for strength and superior corrosion resistance.
- G. Motor. The mixer shall be mechanically operated by a submersible motor that meets the following criteria.
1. Direct Drive, with no gearbox and no lubrication maintenance required.
  2. Designed for submersible operation. Mixer design shall include flow sleeve or housing around motor to provide water flow past motor per submersible motor design criteria to lower the total motor temperature and increase winding life.
  3. Designed for Continuous Operation without overheating or compromising motor life expectancy. Constant, full speed operation, variable frequency drive or other method of speed reduction not required and not allowed.
  4. 120 VAC, 20 Amp power source shall be supplied by others and not the mixer manufacturer.
- H. SCADA and Controls. The mixer shall have the option to add an Electric Control Box including a motor current indicator in a 4-20mA analog output and remote on/off control via 24VDC relay.
- I. Electrical Control Box. The mixer equipment shall be supplied with a Control Box capable of disconnecting 120 VAC outgoing power to the mixer equipment and meeting the following criteria:
1. NEMA 4X enclosure shall be provided with protection against condensation and moisture in a marine environment.
  2. Control Box shall be UL 508 Listed for sound electrical design and safety.
  3. Control Box shall include exterior mounted HOA selector switch with switch position output signal, definite purpose contactor for mixer control, exterior display showing green run, red fault indication, and motor operating amperage, grounding grounding lug, 120 VAC standard three-prong male molded plug, and locking latch for security.
  4. Control Box shall include dry contact outputs for run and fault indication, and 4-20 mA analog output scaled to motor current. Control Box shall include a 24 VDC relay to allow for remote on and off control of the mixer. Integration of 4-20 mA output and remote on/off relay into site PLC/RTU shall be provided by others and not by the mixer equipment manufacture.

5. Control Box requires a 120 VAC power source, Minimum 20 Amp rated service located near the final placement of the Control Box.
  6. Timer to be 16A resistive, 8A FLA rated, single and double pole contact configuration, 8V A power consumption, CR2032(1.5V Lithium) with 3 years battery life, 8 On and Off cycles, one minute minimum interval.
- J. Low Elevation Intake: The circulation equipment shall be supplied with an intake capable of being positioned at the lowest elevation of the tank or reservoir floor. The intake level shall bring water into the circulation equipment at horizontal layer within 6 inches (15 cm) of the tank or reservoir floor.
- K. The circulation equipment shall be NSF/ANSI Standard 61 and NSF/ANSI Standard 372 listed for safe contact with potable water. The mixer shall be NSF/ANSI Standard 61 listed to be safely in contact with a potable water volume as low as 5,000 gallons.
- L. Maintenance Requirements. The circulation equipment shall operate normally with the following maintenance features.
1. No scheduled lubrication is required of any system components including motor.
  2. No spare parts shall be required to be kept on hand.
- M. Equipment Support. The mixer manufacturer shall offer factory support with the following staff and support services.
1. Customer Service, Application Engineering, and Equipment Engineering staff available by email or toll-free phone.
  2. Public website with detailed information available describing the mixer for this project and related applications of this equipment into potable water tanks and reservoirs.
  3. Service plans for preventative maintenance and continued technology improvements for the specified mixer.

## **PART 3 – EXECUTION**

### **3.01 INSTALLATION**

- A. The circulation equipment manufacturer shall have the capability to provide Installation, Startup, and On-Site Water Testing Services to insure (a) proper machine spatial placement in the reservoir, and (b) proper intake depth setting.
- B. Contractor to provide conduit and electric service from the base of the tank (at the electric panel) up to the roof or utilize the existing conduit if available. All conduit to be galvanized and continuous from ground to roof with no openings.
- C. Contractor to supply coupling and junction box on the roof with watertight seal for electric line and connection point next to the roof hatch for retrieval chain and electric line.

- D. The device is to be installed per manufacturer's recommendations with a weather tight seal on the roof.
- E. Mixer to be installed above the bowl bottom (approximately 4 to 12 inches) using the manufacturers suspension kit.

### **3.02 MOUNTING PANEL**

- A. Construct a mounting panel for the mixer controls. Use (2) 8 ft. long, 2½ in. Schedule 40 galvanized steel pipe supports with threaded end caps.
- B. Dig (2) 8 in. holes 3 ft. down and 3 ft. on center, lay a prefabricated concrete base pad or a layer of concrete a minimum of 2 inches deep into the bottom of each hole and allow the concrete to harden. Set pipes into the ground and pour remaining concrete into the hole.
- C. Pour a 3 ft. by 4 ft. concrete pad 3.5 inches deep around the control panel. Pad top to be level with the surrounding ground.
- D. Use ultraviolet protected plastic deck boards for the panel. Panel to consist of four (4) boards for the panel spaced ½ in apart. Attach to the pipes using 3/8 in. galvanized u-bolts, 4 per board.

### **3.03 ELECTRICAL SUPPLY**

- A. There is a 120 volt power available at a leg.
- B. Coordinate with owner and connect electrical source to the mixer controls.
- C. Bury all exterior wiring underground from electrical source to the mixer controls.



## **SECTION 16 05 04**

### **ELECTRICAL – ELECTRIC CONDUIT AND LIGHTING**

#### **PART 1 – GENERAL**

##### **1.01 SECTION INCLUDES**

- A. Furnish and coordinate all labor, equipment, materials, tools, testing, and temporary work necessary to replace light fixtures in the dry interior.

##### **1.02 REFERENCES**

- A. NEC.
- B. FAA.
- C. Local Codes and Regulations.

##### **1.03 OMISSIONS**

- A. The specifications include all work and materials necessary for completion of the work. Any incidental items of material, labor, or detail required for the proper execution and completion of the work are included.

##### **1.04 WORK INCLUDED**

- 1. Replace light fixtures.
- 2. Electrical conduit repair.
- 3. Change all light bulbs in the dry interior.

##### **1.05 WORKMANSHIP**

- A. Provide material and workmanship necessary to produce a first class job.

##### **1.06 ELECTRICIAN QUALIFICATIONS**

- A. The electrician must conform to all licensing and/or certification requirements of the State.
- B. The electrician shall be experienced in rigging and elevated work.
- C. All contractors shall be prequalified.

##### **1.07 SUBMITTALS**

- A. Material Safety Data Sheets (MSDS): For all items as required by law.
- B. Submit materials at least one (1) week prior to the preconstruction meeting.

## **PART 2 – PRODUCTS**

### **2.01 GENERAL**

- A. Use electrical materials and equipment designed and manufactured with UL Label.
- B. Supply all new equipment and materials from products of the same manufacturer.
- C. Furnish all equipment and materials from an established, reputable manufacturer of top quality construction, design, and guaranteed to perform the service required.

### **2.02 CONDUIT**

- A. Use galvanized rigid steel conduit.

### **2.03 CONDUIT FITTINGS and BOXES**

- A. Use standard threaded-type of cast ferrous alloy conduit fittings to suit the location and purpose. Use fittings manufactured by Crouse-Hinds, Appleton Electric, or equal.
- B. Use waterproof and bugproof galvanized malleable or cast iron, or corrosion resistant stainless steel boxes.

### **2.04 LIGHT FIXTURES**

- A. Access tube 200 watt incandescent, wall mounted, watertight fixtures with globe, guard, and lamp equal to HUBBEL #VWX-302.
- B. Lighting fixtures and globes to be by Hubbell Lighting, Inc., Greenville, South Carolina 864-678-1000 or approved equal.

## **PART 3 – EXECUTION**

### **3.01 LIGHT FIXTURE REPLACEMENT**

- A. Replace the damaged light fixtures. There are two (2) fixtures to replace.
- B. All wiring to be inside conduit and all conduit to be sealed leaving no exposed wiring.
- C. Any new conduit is to match the existing conduit.
- D. Lights to be installed next to the ladder and are not to interfere with climbing.
- E. Contractor to ensure lights work after installation.
- F. Payment is separate line item “Light Fixture Replacement” which the owner reserves the right to delete.

### **3.02 ELECTRICAL CONDUIT REPAIR**

- A. Replace the damaged electrical conduit in the bottom of the access tube.

- B. All wiring to be rerouted inside the new conduit and all conduit to be sealed leaving no exposed wiring.
- C. Any new conduit is to match the existing conduit.
- D. Payment is incidental to the project.

**3.03 REPLACE LIGHT BULBS**

- A. Replace all dry interior and aviation light bulbs with LED light bulbs
- B. Dry interior bulbs to be bright white LED bulbs with a minimum brightness of 800 lumens and a color of light at a minimum of 5,000K and a minimum rated life of 25,000 hours.
- C. The aviation light bulbs to be LED with a minimum brightness of 1600 lumens and a color of light at a minimum of 5,000K, and a minimum rated life of 25,000 hours.
- D. Change bulbs after all blast and paint equipment has been removed from the tank.
- E. All bulbs to have the same color and brightness throughout the dry interior.
- F. Payment is incidental to the project.